

NO.	PART NAME	PART#	REQ'D	MATERIAL
1	EYEBOLT 1"X6"	EBR16HP	1	CARBON STEEL
2	HEAVY SQUARE NUT 1"-8	N1	1	CARBON STEEL
3	FLAT WASHER 1"	WASH1P	1	CARBON STEEL
4	PIN 3/8"X2 1/2"	PIN375	1	CARBON STEEL

APPLY A BEAD OF WELD TO THE TWO END THREADS AFTER INSTALLING WASHER AND NUT

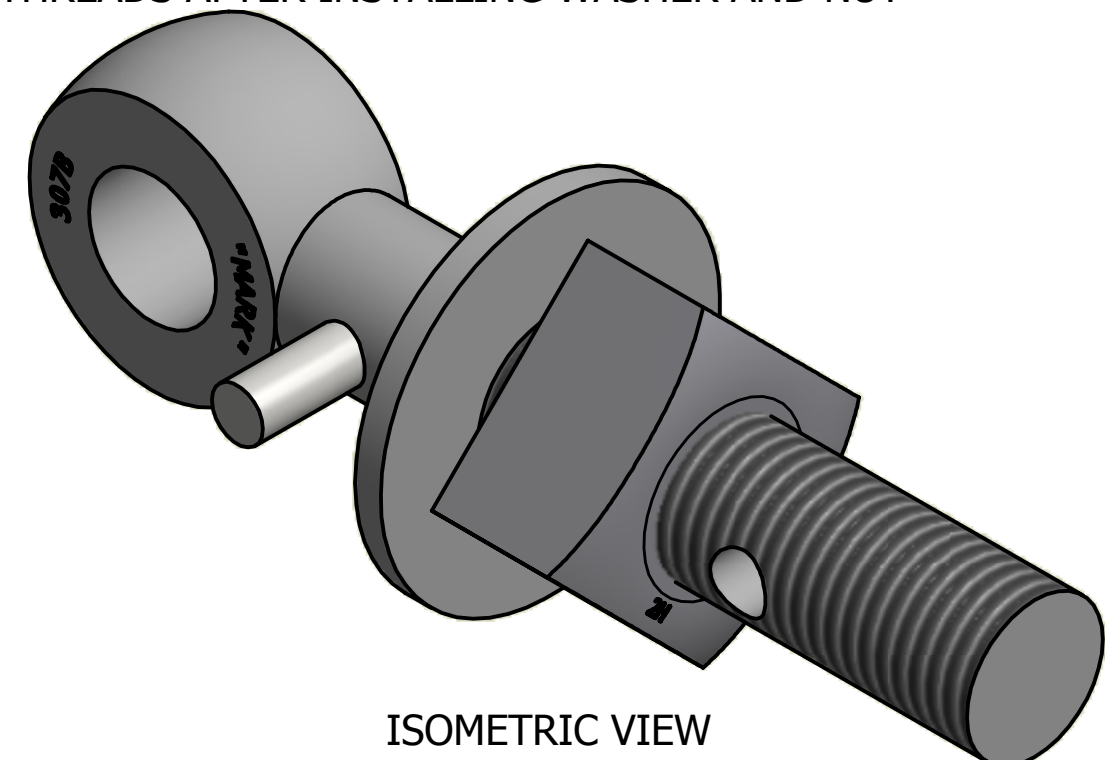

REV	BY	DATE	DESCRIPTION
E	CHL	8-21-13	CHANGED EYEBOLT MATERIAL
D	CHL	3-13-03	REPLACED A16204,EBR16HPR W/EBR16HP, WELD STOP, ALL DIMS TO FRACTIONAL
C	CHL	11-26-01	REPLACED SN14S W/A16204
B	CHL	4-25-01	REPLACED WASH1 WITH WASH1P
A	FOD	8-4-99	UPDATED B.O.M., ITEM # 1 WAS EB16HPR

UNLESS OTHERWISE SPECIFIED DIMENSIONAL TOLERANCES	DRAWN BY:	FOD
FRACTIONAL: ±1/16	CHECKED BY:	SAB
X.XX: ±.03	PROTOTYPE BY:	FOD
X.XXX: ±.015	PROTOTYPE DATE:	5/11/1999
ANGULAR: ±1°	APPROVED FOR PRODUCTION BY:	SAB
THIS PRINT, PROPERTY OF SALCO PRODUCTS INC., CONTAINS PROPRIETARY INFORMATION AND MUST NOT BE COPIED, REPRODUCED, OR USED DETRIMENTALLY TO OUR INTEREST.	PRODUCTION DATE:	5/11/1999
THIRD ANGLE PROJECTION		

SALCO PRODUCTS, INC.

PART NAME: **EYEBOLT ASSEMBLY 1"X6"**

MATERIAL: **SEE BOM**

PROJECT #: SHEET #: **1 OF 1** SCALE: **1:1**

DRAWING #: **B13426** PART #: **EB16HAP**