

NO	PART NAME	PART #	REQ'D	MATERIAL
1	EYEBOLT 7/8"X5"	EBR785H3S6P	1	316 SS
2	HEAVY HEX NUT 7/8"-9	N78XS6H	1	416 SS
3	PIN 3/8"X2 1/2"	PIN375SS	1	316 SS
4	FLAT WASHER 7/8" SAE	WASH78S6	1	316 SS

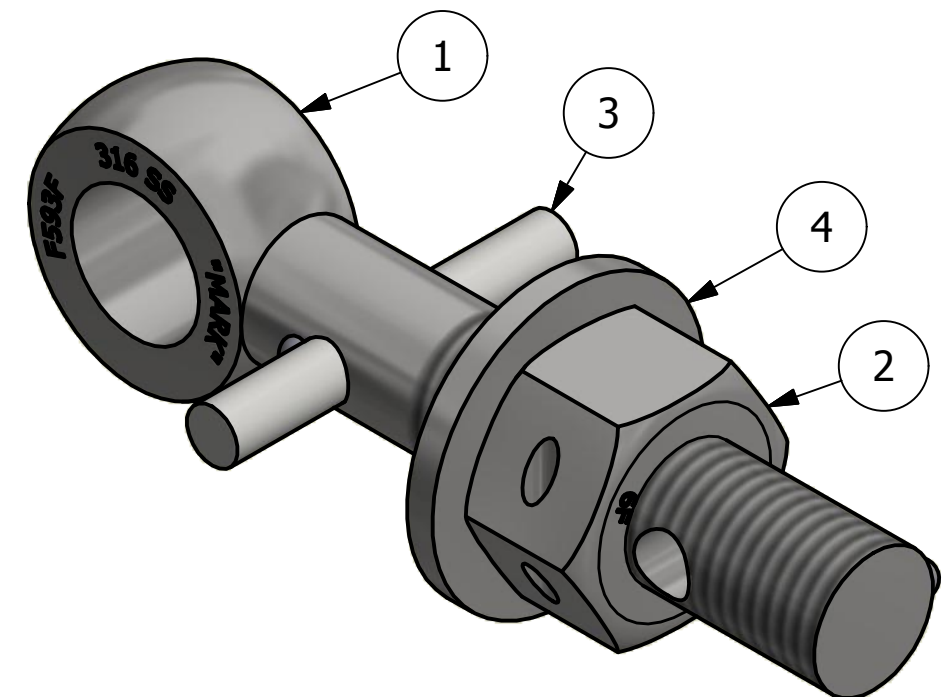

ISOMETRIC VIEW

REV	BY	DATE	DESCRIPTION
A	JG	7-27-18	EBR785H3S6P WAS EBR785H3S6PR; UPDATED DIMENSIONS

SALCO PRODUCTS, INC.

PART NAME: EYEBOLT ASSEMBLY 7/8"X5"

MATERIAL: SEE BOM

PROJECT #: 020829 SHEET #: 1 OF 1 SCALE: 1:1

DRAWING #: B17423 PART #: EB785XHH3AS6P

UNLESS OTHERWISE SPECIFIED DIMENSIONAL TOLERANCES	DRAWN BY:	ACC
FRACTIONAL: ±1/16	CHECKED BY:	PJG
X.XX: ±.03	PROTOTYPE BY:	ACC
X.XXX: ±.015	PROTOTYPE DATE:	11/14/2002
ANGULAR: ±1°	APPROVED FOR PRODUCTION BY:	PJG
DEBURR ALL SHARP EDGES. ALL MACHINED SURFACES TO HAVE A 125 RMS FINISH UNLESS NOTED OTHERWISE.	PRODUCTION DATE:	11/14/2002
THIRD ANGLE PROJECTION		

THIS PRINT, PROPERTY OF SALCO PRODUCTS INC., CONTAINS PROPRIETARY INFORMATION AND MUST NOT BE COPIED, REPRODUCED, OR USED DETRIMENTALLY TO OUR INTEREST.