

NO.	PART NAME	PART#	REQ'D	MATERIAL
1	QUICK CONNECT ADAPTER 2" THREAD ON	K2SMP	1	316 SS
2	CHAIN LINK 3/8"	SC80	5	18-8 SS

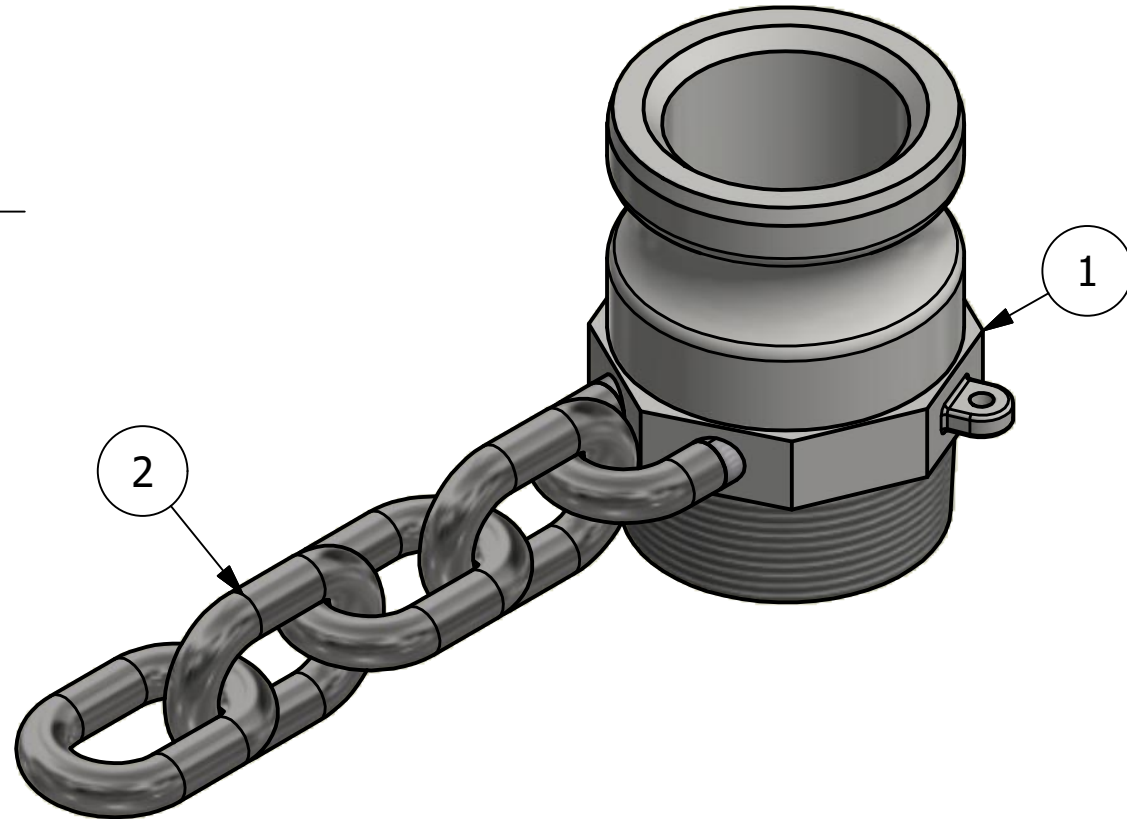
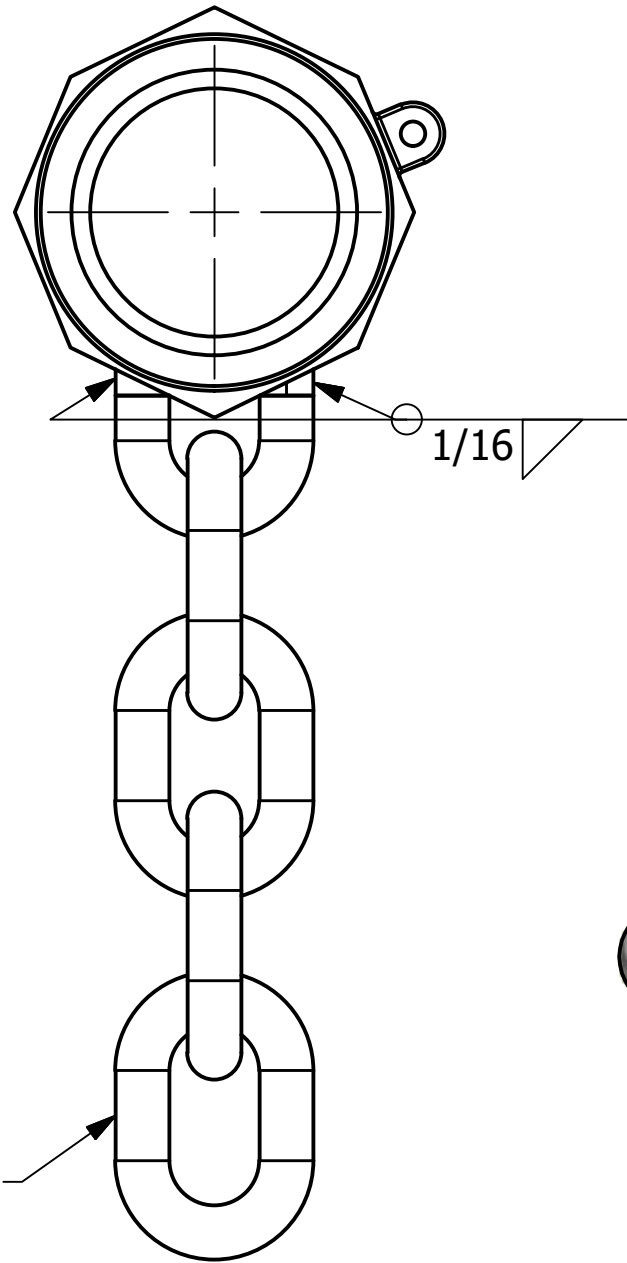

4 LINKS ACTUAL
5TH CUT FOR WELDING

NOTES:
1. SEE DOCUMENTS WPS-T06 & WPS-T07 FOR WELDING PROCEDURES.
2. WELD ACCEPTANCE CRITERIA TO MEET DOCUMENT D-005.

REV	BY	DATE	DESCRIPTION
B	WEB	4/28/21	UPDATED WELD PROCEDURE TO WPS-T06 & WPS-T07; ADDED D-005 NOTE; UPDATED TITLE BLOCK; SCALE WAS 1:1; DRAWING # WAS B34308
A	JG	12/13/16	UPDATED K2SMP, TITLEBLOCK, NOTES

UNLESS OTHERWISE SPECIFIED DIMENSIONAL TOLERANCES		DRAWN BY:	TAK
FRACTIONAL:	±1/16	CHECKED BY:	CHL
X.XX:	±.03	PROTOTYPE DATE:	10/8/2012
X.XXX:	±.015	APPROVED FOR PRODUCTION BY:	CHL
ANGULAR:	±1°	PRODUCTION DATE:	5/2/2013
DEBURR ALL SHARP EDGES. ALL MACHINED SURFACES TO HAVE A 125 RMS FINISH UNLESS NOTED OTHERWISE.		SIZE:	B
THIRD ANGLE PROJECTION		DRAWING #:	14894

SALCO PRODUCTS, INC.		
PART NAME: QUICK CONNECT ADAPTER 2" THREAD ON		
MATERIAL: SEE BOM		
PROJECT #:	SHEET #:	SCALE:
120905FR	1 OF 1	3:4
PART #: K2SMPA		