

| NO. | PART NAME | PART# | REQ'D | MATERIAL |
|-----|--------------------------------|----------|-------|----------|
| 1 | HEX LOCK NUT 1/4"-20 | HCN20S | 1 | 18-8 SS |
| 2 | CHAIN LINK 1/4" | SC25S | 20 | 18-8 SS |
| 3 | S-HOOK 1/4"X2 1/2" | SC25SHS | 1 | 18-8 SS |
| 4 | LOCK RING 2" | SS2TCLR | 1 | 304 SS |
| 5 | QUICK CONNECT CAP 2" THREAD ON | TE20SDCL | 1 | 316L SS |
| 6 | HEX CAP SCREW 1/4"-20X1 1/4" | TE2CLRBS | 1 | 18-8 SS |
| 7 | DUST CAP GASKET 2" | TE2DCG07 | 1 | VITON B |
| 8 | FLAT WASHER 1/4" SAE | VAISW30 | 2 | 18-8 SS |

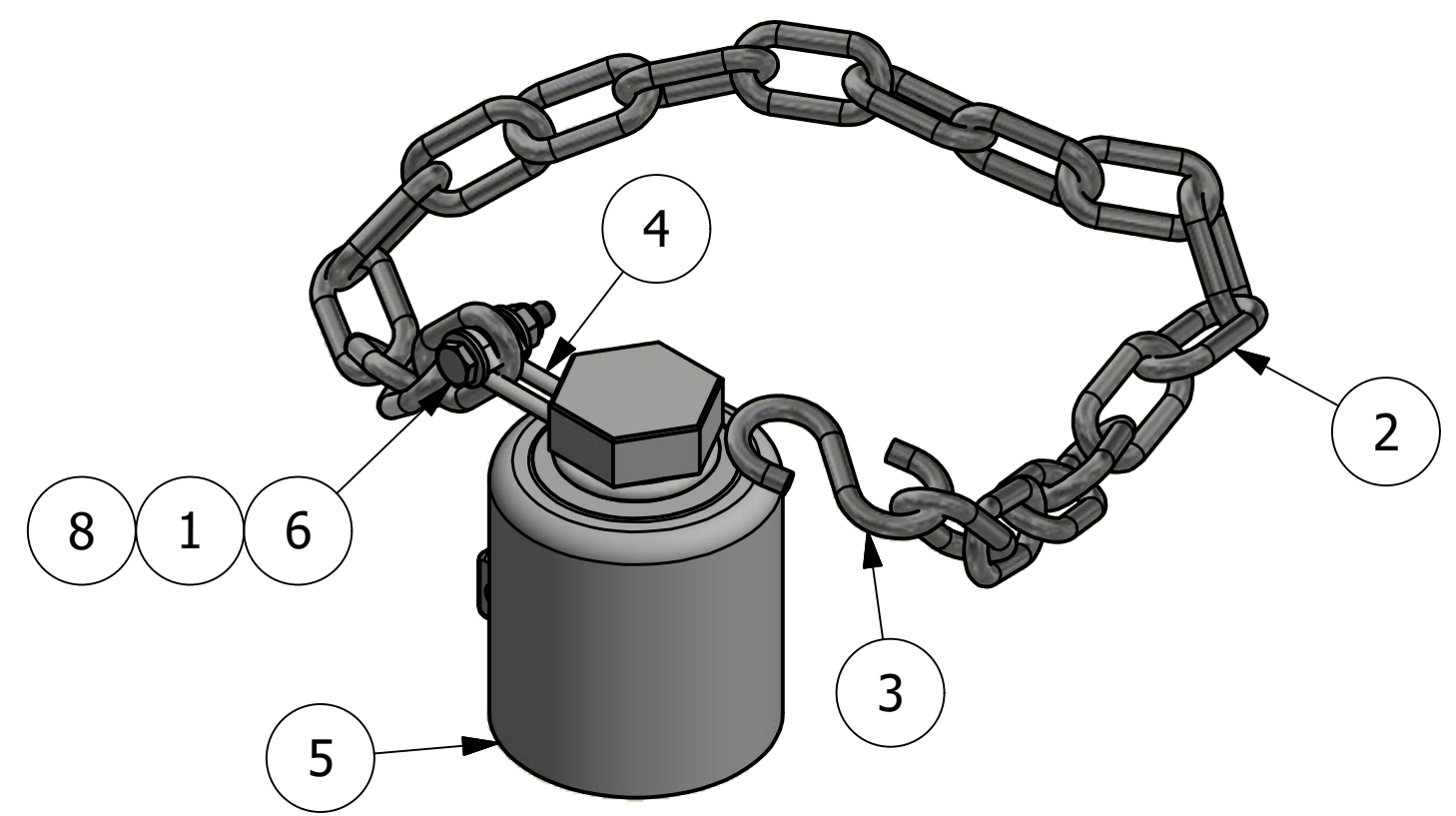
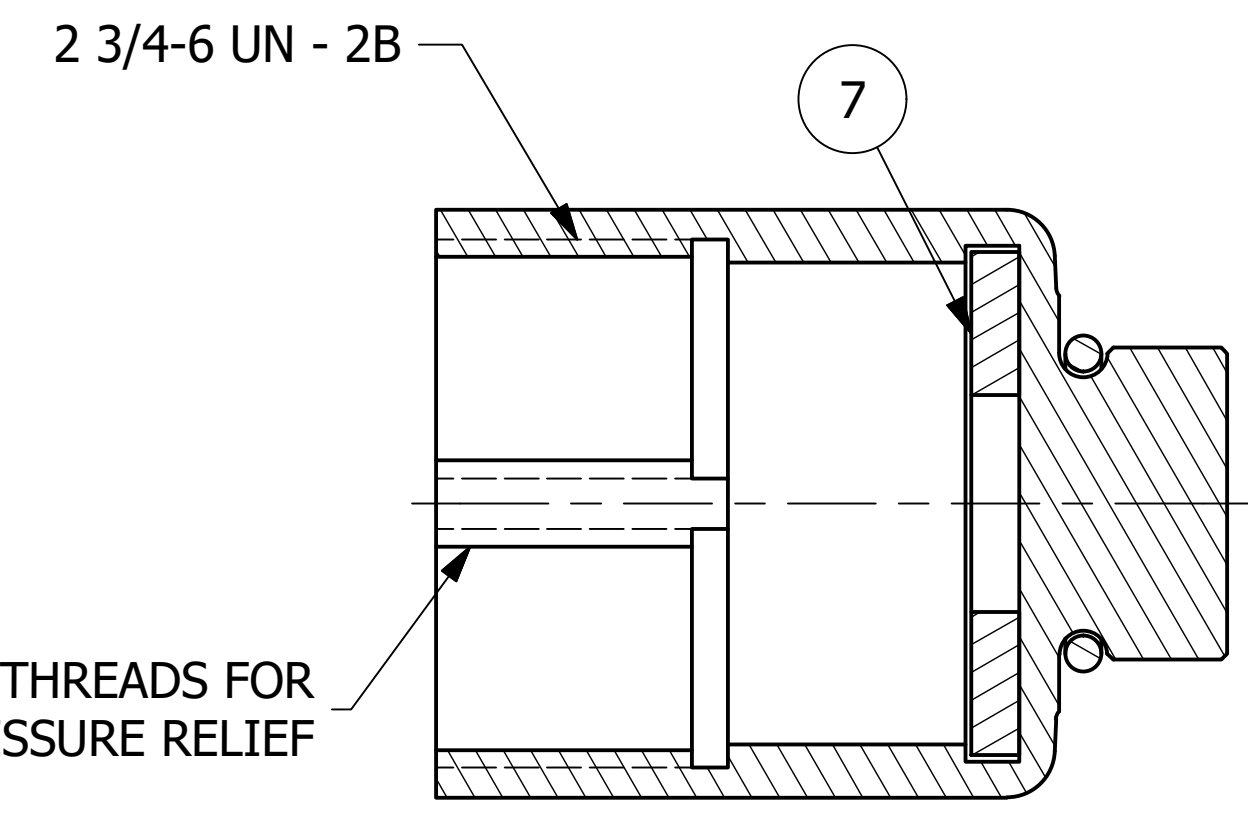

| REV | BY | DATE | DESCRIPTION |
|-----|-----|---------|-----------------------------------------------------------------|
| B | CHL | 12/3/20 | REPLACED TE2DDCG7 W/TE2DCG07, UPDATED TITLEBLOCK, UPDATED VIEWS |
| A | GS | 5/31/12 | DRAWING ADDED TO NETWORK. |

| | |
|---------------------------------------------------------------------------------------------------------------------------------------------------------------------------------------------------------------------------------|-------------------------------------------------------------------------------------------------------------------------------------------------------------|
| UNLESS OTHERWISE SPECIFIED DIMENSIONAL TOLERANCES FRACTIONAL: ±1/16 X.XX: ±.03 X.XXX: ±.015 ANGLE: ±1° DEBURR ALL SHARP EDGES. ALL MACHINED SURFACES TO HAVE A 125 RMS FINISH UNLESS NOTED OTHERWISE | DRAWN BY: GS CHECKED BY: CHL PROTOTYPE DATE: 5/7/2012 APPROVED FOR PRODUCTION BY: CHL PRODUCTION DATE: 5/31/2012 SIZE: C DRAWING #: 33148 |
|---------------------------------------------------------------------------------------------------------------------------------------------------------------------------------------------------------------------------------|-------------------------------------------------------------------------------------------------------------------------------------------------------------|

SALCO PRODUCTS, INC.

PART NAME: **TOP FITTING CAP 2" THREADED**

MATERIAL: **SEE BOM**

PROJECT #: **120505** SHEET #: **1 OF 1** SCALE: **1:1**

PART #: **TE20SDLDC07A**