

NO.	PART NAME	PART#	REQ'D	MATERIAL
1	DUST CAP 2"	K20IDC207A	1	DI
2	QUICK CONNECT ADAPTER 2" THREAD ON	K2IMPA	1	DI

NOTE:
GASKET MATERIAL IS SILICONE VMQ.

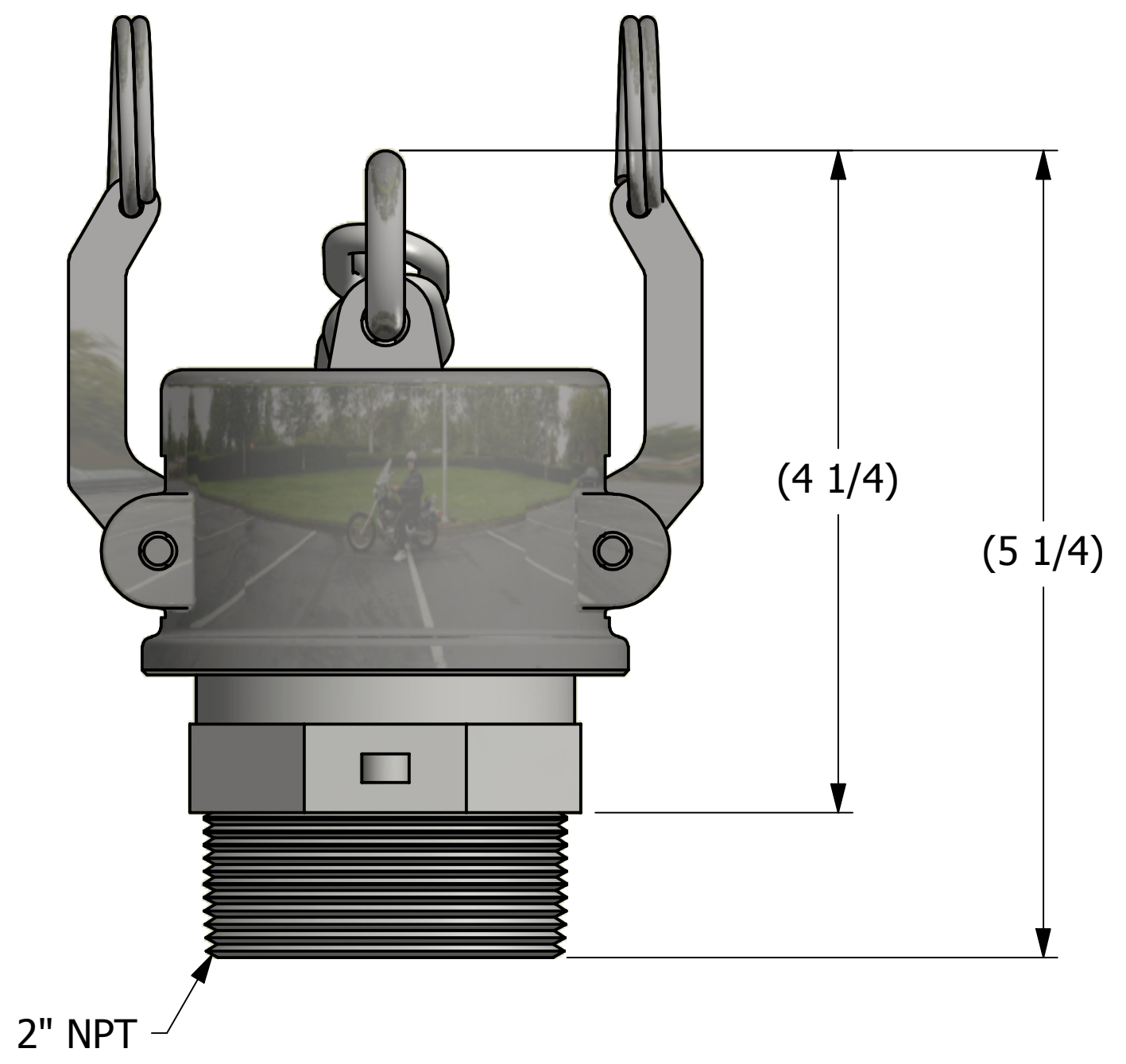

21 LINKS ACTUAL

5 LINKS ACTUAL

REV	BY	DATE	DESCRIPTION
B	RJP	6-12-14	UPDATED DESIGN OF K20IDC207A
A	KHK	2-14-13	RELEASED FOR PRODUCTION

<small>UNLESS OTHERWISE SPECIFIED DIMENSIONAL TOLERANCES FRACTIONAL: ±1/16 X.XX: ±.03 X.XXX: ±.015 ANGLE: ±1° DEBURR ALL SHARP EDGES. ALL MACHINED SURFACES TO HAVE A 125 RMS FINISH UNLESS NOTED OTHERWISE.</small>	DRAWN BY:	GS
	CHECKED BY:	CHL
	PROTOTYPE BY:	GS
	PROTOTYPE DATE:	1/11/2013
	APPROVED FOR PRODUCTION BY:	CHL
THIRD ANGLE PROJECTION	PRODUCTION DATE:	2/14/2013

SALCO PRODUCTS, INC.

PART NAME:
UNLOADING ASSEMBLY 2"

MATERIAL: **SEE BOM**

PROJECT #: **130111FR** SHEET #: **1 OF 1** SCALE: **1:1**

DRAWING #: **C35097** PART #: **K20IUMP207A**