

Standard Arrangement

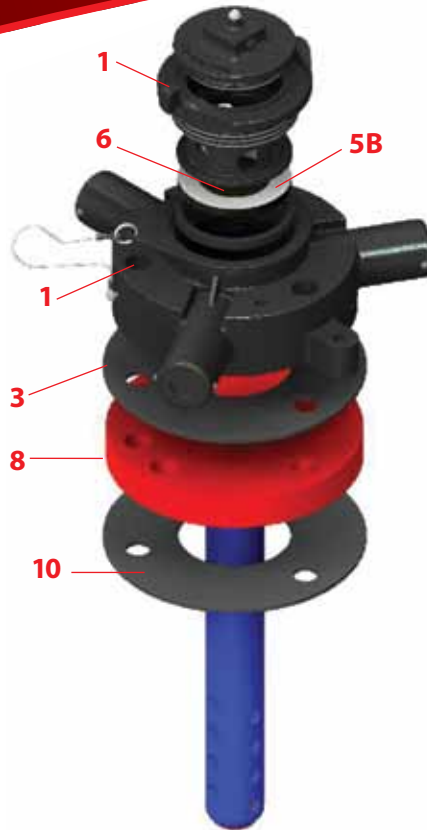

No Surge Protector in Unit.  
Flanged Surge Protector Below Unit.

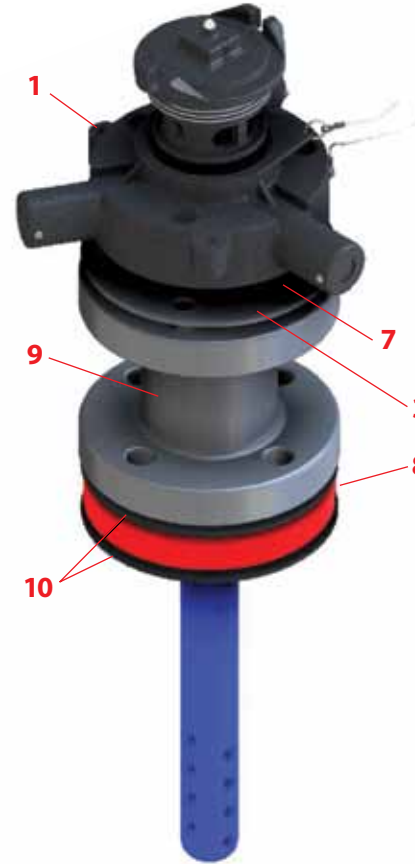

No Surge Protector in Unit.  
Rupture Disc, Spool and Flanged Surge Protector are Below Unit.

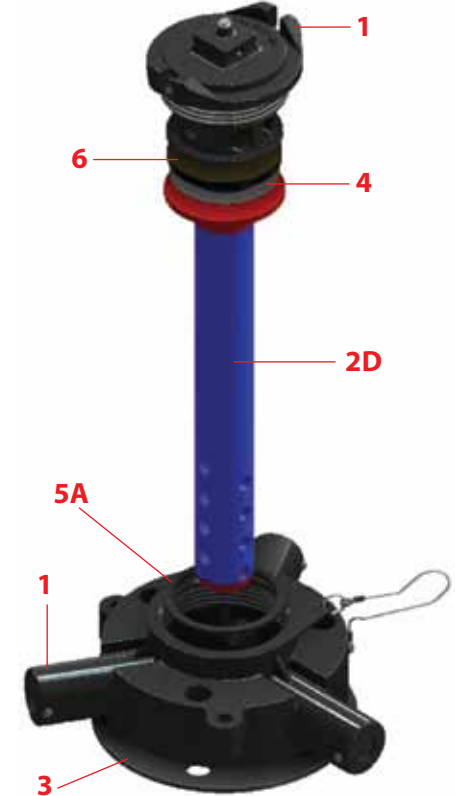

HAZARSOLVE Surge Protector,  
for Rubber Lined Cars

NO.	Part Name	Part #	NO.	Part Name	Part #	NO.	Part Name	Part #
1	Quick Inspect Safety Vent	QI261BSA	3	Quick Inspect Flange Gasket	FG550##	7	Rupture Disk	RD165HCL
2A	Surge Protector (Noryl)	DSP3313	4	QI Rupture Disk Gasket	QI261RDG##	8	Surge Protector (Salco PE)	HSSPRD7, HSSPRD7MT
2B	Surge Protector (Ryton)	DSP3313R	5A	QI Retainer Gasket	QI261G##	9	Rubber-lined Dual Flange	DF55RLB
2C	Surge Protector (SS)	DSP3313SS6	5B	QI Retainer Gasket (Thick)	QI261DG##	10	150# Flange Gasket, 2-1/2"	FG225150##
2D	Surge Protector (Salco PE)	HSSPRD33, HSSPRD33MT	6	Rupture Disk	RD165ST, RD165PL2			