

NO.	PART NAME	PART#	REQ'D	MATERIAL
1	ELBOW 2" X 90°	2A90SCH40ELB	1	ASTM B361 WP6061S
2	PIPE 2"	A50714	1	6063-T6 ALUMINUM
3	PIPE 2"	A50715	1	6063-T6 ALUMINUM
4	PIPE 2"	A50716	1	6063-T6 ALUMINUM
5	SQUARE FLANGE 2"	PD2ASF01	1	ASTM B209 6061-T62/T651

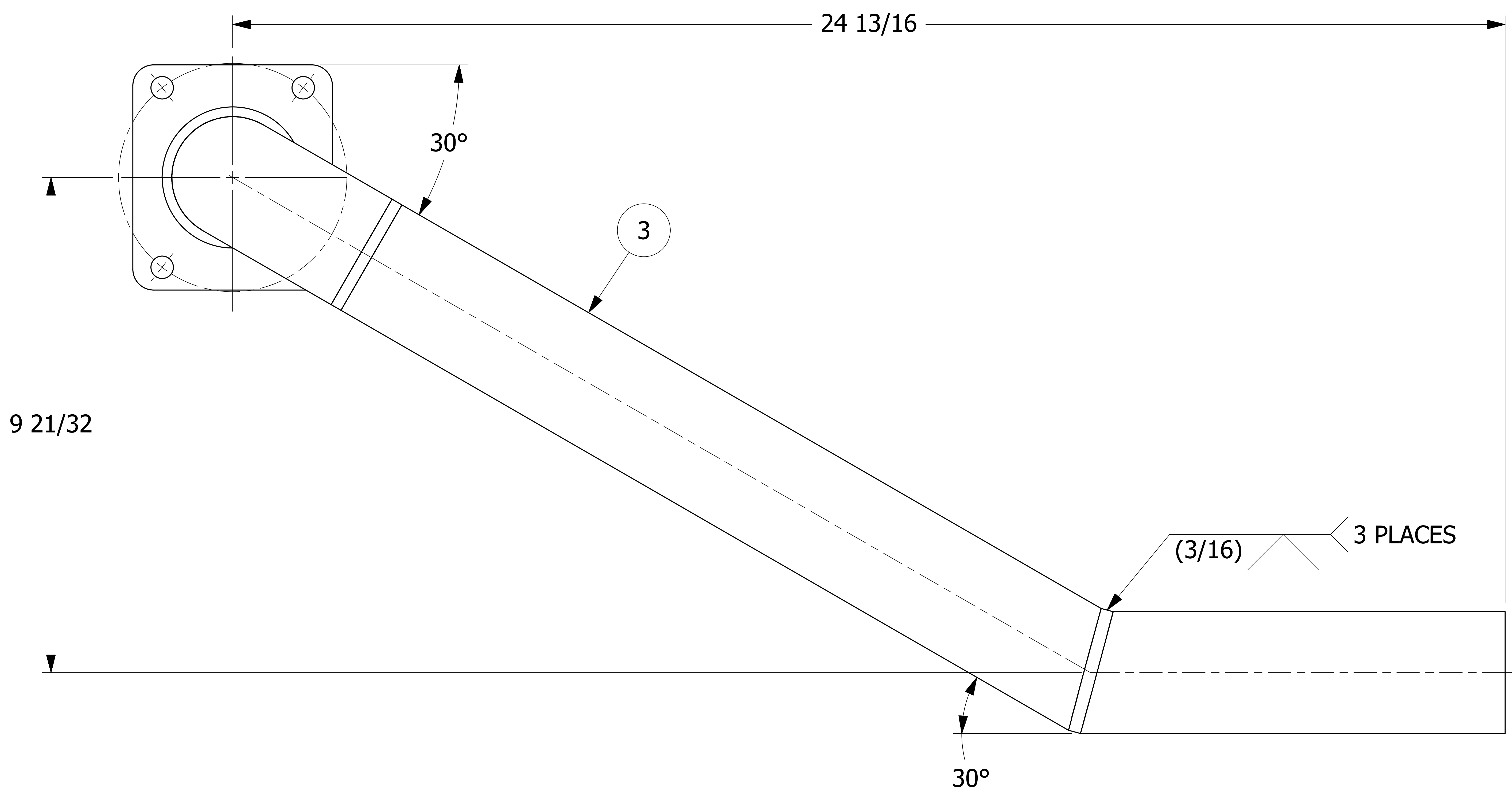

- NOTES:
- TEST PER Q-2.15.7.
 - SEE DOCUMENTS WPS-M09, WPS-T01, & WPS-P01 FOR APPROVED WELD PROCEDURES.
 - WELD ACCEPTANCE CRITERIA TO MEET DOCUMENT D-005.

REV	BY	DATE	DESCRIPTION
C	CHL	9/29/20	Q-2.15.7 WAS QAP4C-1, REPLACED DSS 12 W/WPS-M09, WPS-T01, WPS-P01, ADDED D-005 NOTE, REPLACED P2A40 W/A50714, A50715, A50716, REMOVED REFERECNE DIMS, DWG# WAS 16231
B	JG	10/23/15	ADDED PIPE LENGTH NOTES
A	WEB	7/15/15	RELEASED FOR PRODUCTION

UNLESS OTHERWISE SPECIFIED DIMENSIONAL TOLERANCES FRACTIONAL: ±1/16 X.XX: ±.03 X.XXX: ±.015 ANGULAR: ±1° DEBURR ALL SHARP EDGES. ALL MACHINED SURFACES TO HAVE A 125 RMS FINISH UNLESS NOTED OTHERWISE. THIRD ANGLE PROJECTION	DRAWN BY: CHL CHECKED BY: ACC PROTOTYPE DATE: 12/20/2011 APPROVED FOR PRODUCTION BY: WEB PRODUCTION DATE: 7/15/2015 SIZE: E DRAWING #: 16230
--	--

SALCO PRODUCTS, INC.

PART NAME: **AIR LINE PIPE 2"**

MATERIAL: **SEE BOM**

PROJECT #: **011001** SHEET #: **1 OF 1** SCALE: **1:1**

PART #: **PD2AIA01**