

NO	PART NAME	PART#	REQ'D	MATERIAL
1	ID PLATE 3" X 3/4"	A15152	.5	ALUMINUM
2	DRIVE SCREW TYPE U #2 X 1/8"	DR218	2	18-8 SS
3	QUICK INSPECT FLANGE GASKET	FG550205	1	BLACK GARLOCK #7986 NEOPRENE
4	QUICK INSPECT SAFETY VENT	QI261BSA	1	BLACK NORYL
5	QI RETAINER GASKET	QI261G205	1	BLACK GARLOCK #7986 NEOPRENE
6	RUPTURE DISC (SOLD SEPERATELY)			

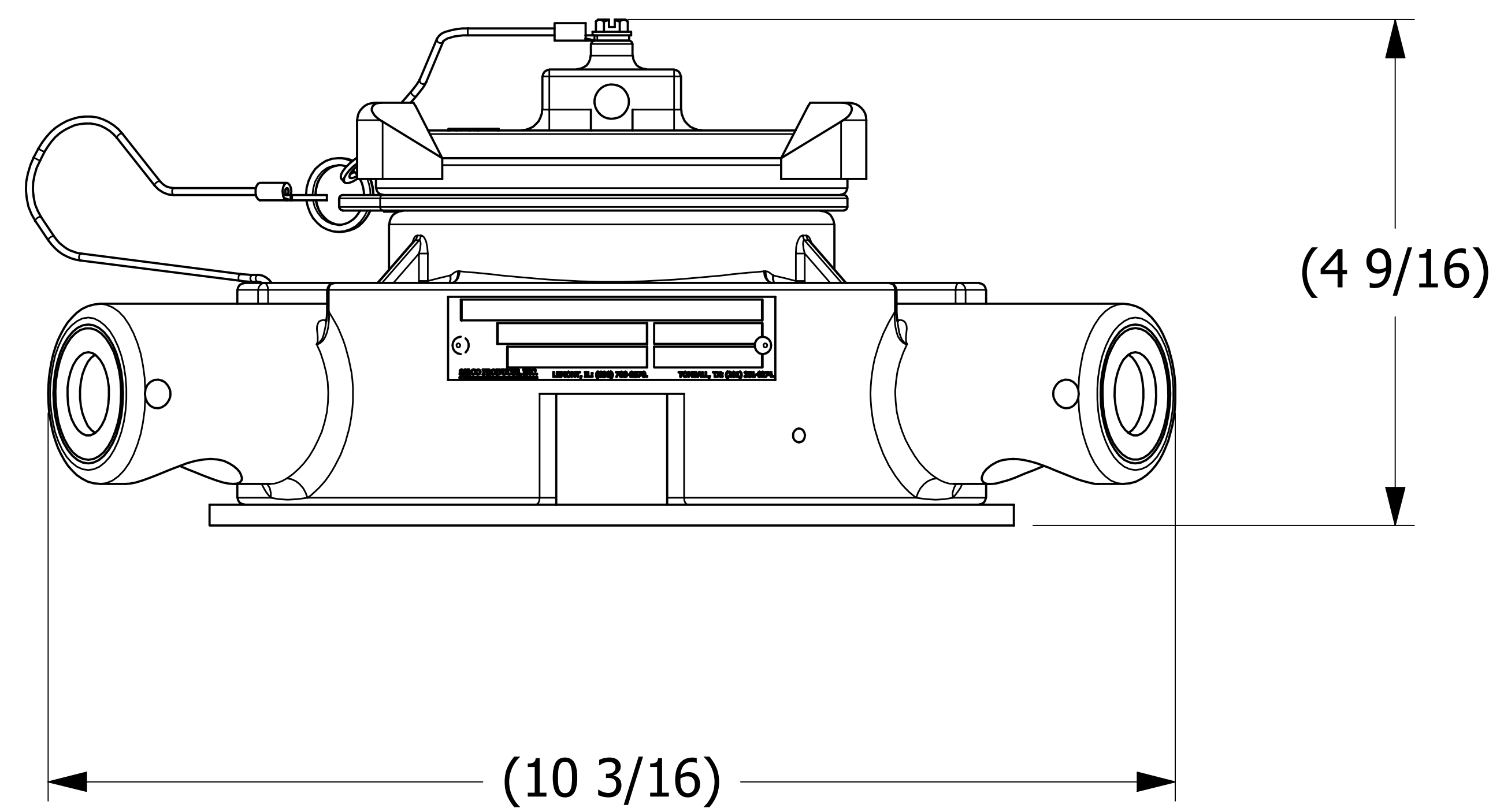
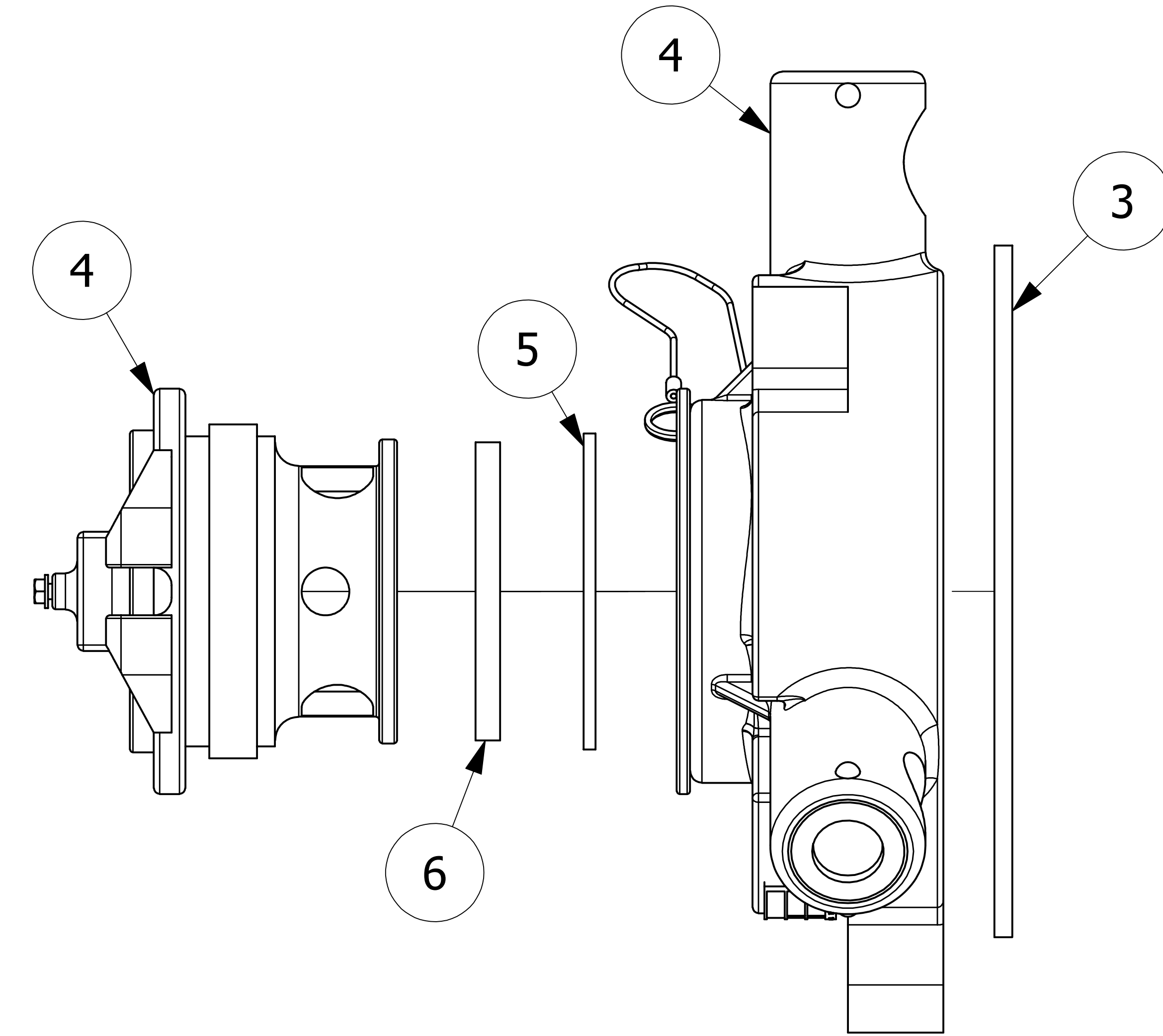
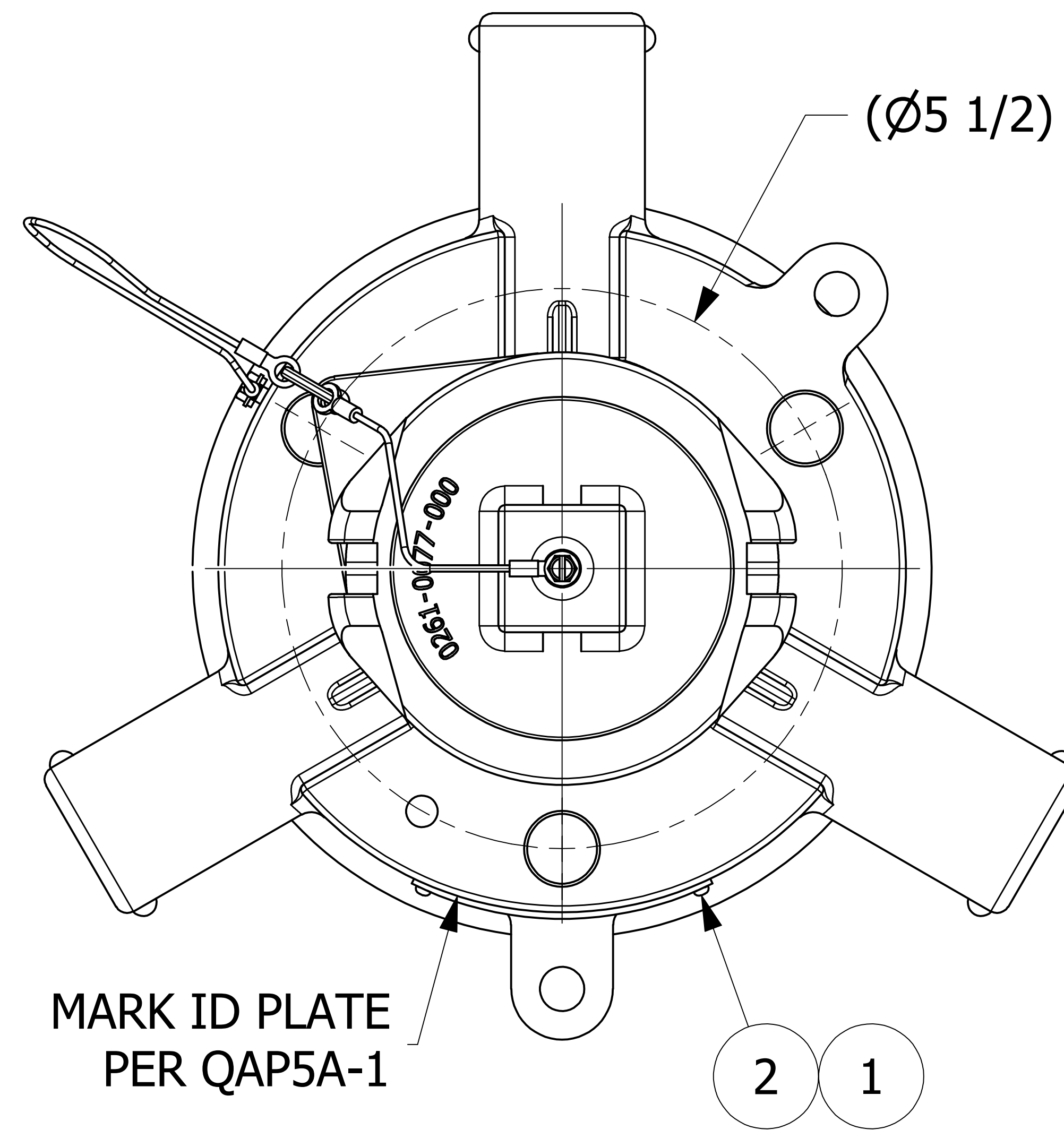

**NOTES:**

1. CUSTOMERS RESPONSIBILITY FOR COMPATIBILITY OF COMMODITY.
2. AAR APPROVAL # PRD-162102.
3. GASKET MATERIAL IS BLACK GARLOCK #7986 PREMIUM GRADE NEOPRENE DURO 60 ± 5 SHORE A. MANUFACTURED DOMESTICALLY. (NY, NY).
4. SEE DOCUMENT QAP5A-1 FOR MARKING PROCEDURE.
5. FASTEN ID PLATE WITH DRIVE SCREWS.

C	JG	2-7-17	AAR APPROVAL # WAS SRD-063000
B	TAK	9-10-13	ADDED A15152, DR218 & QAP5A-1 NOTE
A	BG	2-14-13	DRAWING RELEASED FOR PRODUCTION
REV	BY	DATE	DESCRIPTION

<small>UNLESS OTHERWISE SPECIFIED DIMENSIONAL TOLERANCES</small> FRACTIONAL: ±1/16 X.XX: ±.03 X.XXX: ±.015 ANGULAR: ±1° <small>DEBURR ALL SHARP EDGES. ALL MACHINED SURFACES TO HAVE A 125 RMS FINISH UNLESS NOTED OTHERWISE.</small> THIRD ANGLE PROJECTION	DRAWN BY:	WEB
	CHECKED BY:	CHL
	PROTOTYPE BY:	WEB
	PROTOTYPE DATE:	12/13/2012
	APPROVED FOR PRODUCTION BY:	BG
	PRODUCTION DATE:	2/14/2013

**SALCO PRODUCTS, INC.**

**QUICK INSPECT SAFETY VENT**

**SEE BOM/NOTE**

PROJECT #:	121212	SHEET #:	1 OF 1	SCALE:	1:1
DRAWING #:	E34822	PART #:	QI261NSPR205A		