

NO.	PART NAME	PART #	REQ'D	MATERIAL
1	QUICK INSPECT RETAINER DISC	QI261RDS	1	NORYL
2	O-RING 3"X1/8"	QI261OR	1	BLACK VITON A

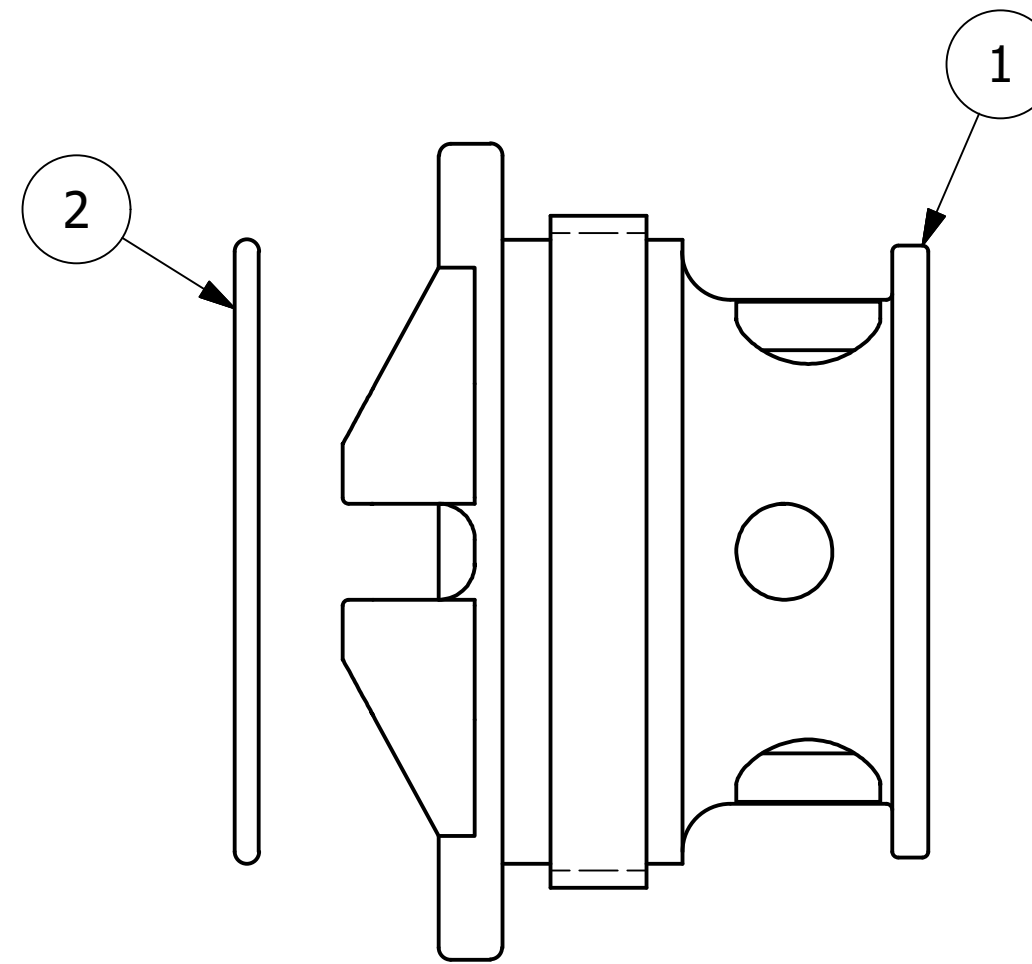
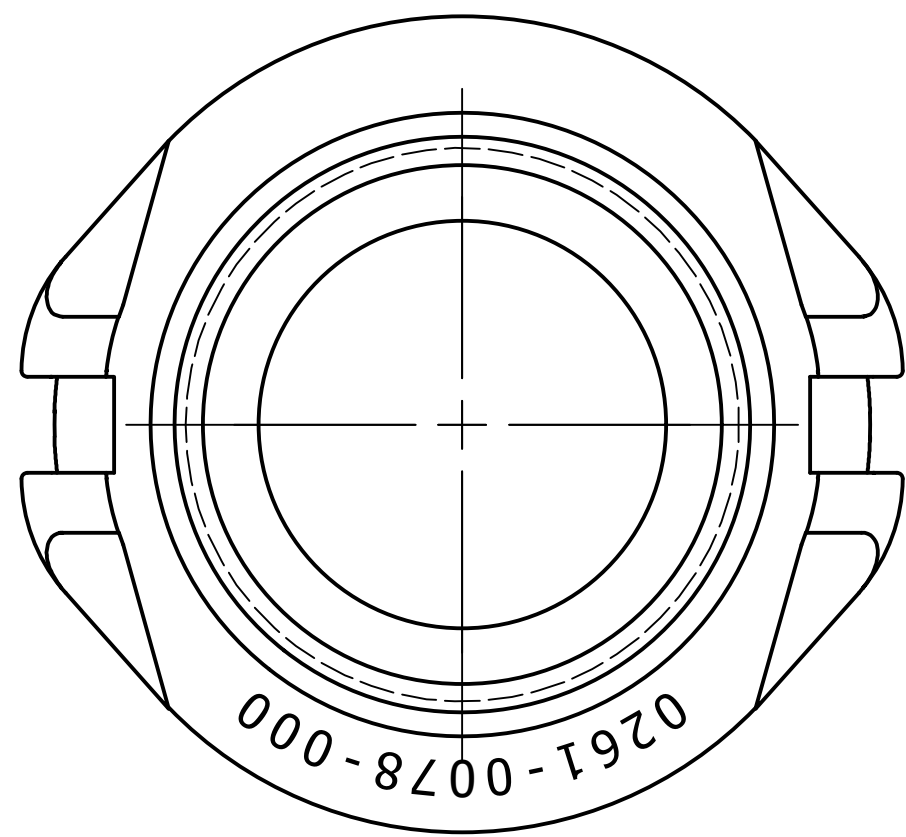

- NOTES:**
1. GLUE O-RING IN TO PLACE WITH 2 DROPS OF GLUE.
 2. GLUE MUST CURE FOR 24 HOURS.

REV	BY	DATE	DESCRIPTION
B	WEB	4/6/23	UPDATED NOTE 1; ADDED CURE TIME NOTE; UPDATED TO CURRENT STANDARDS
A	MRC	4/17/00	CHANGED DESCRIPTION & ADDED NOTE

UNLESS OTHERWISE SPECIFIED DIMENSIONAL TOLERANCES FRACTIONAL: $\pm 1/16$ X.XX: $\pm .03$ X.XXX: $\pm .015$ ANGLE: $\pm 1^\circ$ DEBURR ALL SHARP EDGES. ALL MACHINED SURFACES TO HAVE A 125 RMS FINISH UNLESS NOTED OTHERWISE	DRAWN BY: MRC
	CHECKED BY:
	PROTOTYPE DATE: 11/4/1999
	APPROVED FOR PRODUCTION BY:
	PRODUCTION DATE:
	SIZE: C
	DRAWING #: 13886

SALCO PRODUCTS, INC.		
PART NAME: QUICK INSPECT RETAINER DISC		
MATERIAL: SEE BOM		
PROJECT #:	SHEET #: 1 OF 1	SCALE: 1 : 1
PART #: QI261RDSA		