

NO	PART NAME	PART#	REQ'D	MATERIAL
1	ID PLATE 3" X 3/4"	A15152	.5	ALUMINUM
2	DRIVE SCREW TYPE U #2 X 1/8"	DR218	2	18-8 SS
3	QUICK INSPECT FLANGE GASKET	FG550V	1	BLACK VITON A
4	SURGE PROTECTOR	HSSPRD33	1	SALCO PE
5	QUICK INSPECT SAFETY VENT	QI261BSA	1	BLACK NORYL
6	QI RETAINER GASKET	QI261G6	1	BLACK VITON A
7	QI RUPTURE DISK GASKET	QI261RDG6	1	BLACK VITON A
8	RUPTURE DISC 165 psi	RD165PL2	1	RYTON

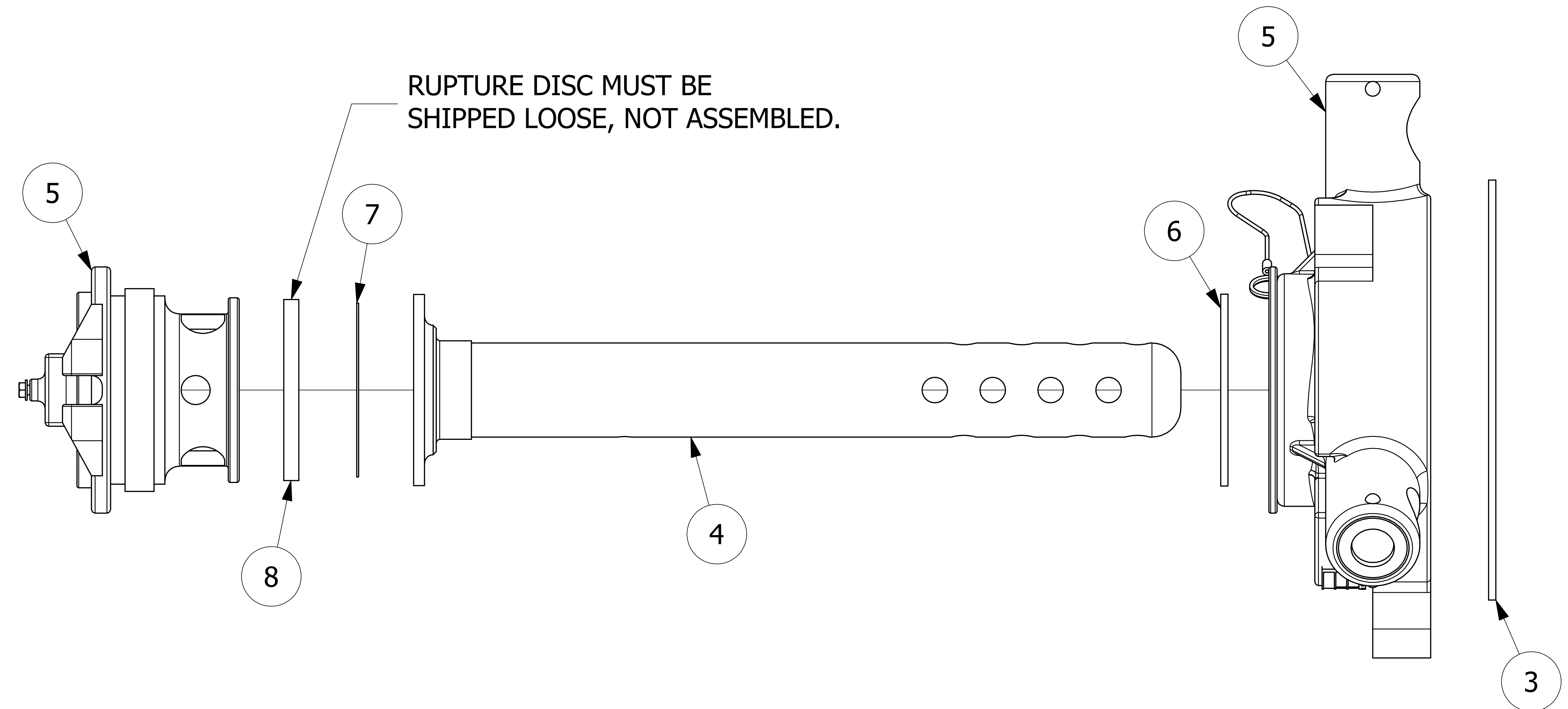

- NOTES:
1. CUSTOMERS RESPONSIBILITY FOR COMPATIBILITY OF COMMODITY.
 2. AAR APPROVAL # PRD-162102.
 3. RUPTURE DISC MUST BE SHIPPED LOOSE, NOT ASSEMBLED.
 4. SEE DOCUMENT QAP5A-1 FOR MARKING PROCEDURE.
 5. FASTEN ID PLATE WITH DRIVE SCREWS.

D	JG	2-7-17	AAR APPROVAL # WAS SRD-063000
C	TAK	9-3-13	ADDED A15152, DR218 & QAP5A-1 NOTE
B	GS	5-22-12	UPDATED DIMENSIONS AND NOTES. REPLACED RD165P WITH RD165PL2.
A	BRG	2-6-09	NEW PART ADDED TO SYSTEM
REV	BY	DATE	DESCRIPTION

UNLESS OTHERWISE SPECIFIED DIMENSIONAL TOLERANCES FRACTIONAL: ±1/16 X.XX: ±.03 X.XXX: ±.015 ANGULAR: ±1° DEBURR ALL SHARP EDGES. ALL MACHINED SURFACES TO HAVE A 125 RMS FINISH UNLESS NOTED OTHERWISE. THIRD ANGLE PROJECTION	DRAWN BY:	CHL
	CHECKED BY:	VD
	PROTOTYPE BY:	CHL
	PROTOTYPE DATE:	9/10/2008
	APPROVED FOR PRODUCTION BY:	VD
	PRODUCTION DATE:	2/6/2009

SALCO PRODUCTS, INC.

QUICK INSPECT SAFETY VENT

MATERIAL: **SEE BOM**

PROJECT #: **080910** SHEET #: **1 OF 1** SCALE: **1:1**

DRAWING #: **E25962** PART #: **QI261HSP06RD1A**