

NO	PART NAME	PART#	REQ'D	MATERIAL
1	ID PLATE 3" X 3/4"	A15152	.5	ALUMINUM
2	DRIVE SCREW TYPE U #2 X 1/8"	DR218	2	18-8 SS
3	QUICK INSPECT FLANGE GASKET	FG55012	1	BLACK VITON® GF-600S
4	SURGE PROTECTOR	HSSPRD33	1	SALCO PE
5	QUICK INSPECT SAFETY VENT	QI261BSA	1	BLACK NORLYL
6	QI RETAINER GASKET	QI261G12	1	BLACK VITON® GF-600S
7	QI RUPTURE DISK GASKET	QI261RDG12	1	BLACK VITON® GF-600S
8	RUPTURE DISC (SOLD SEPARATELY)			

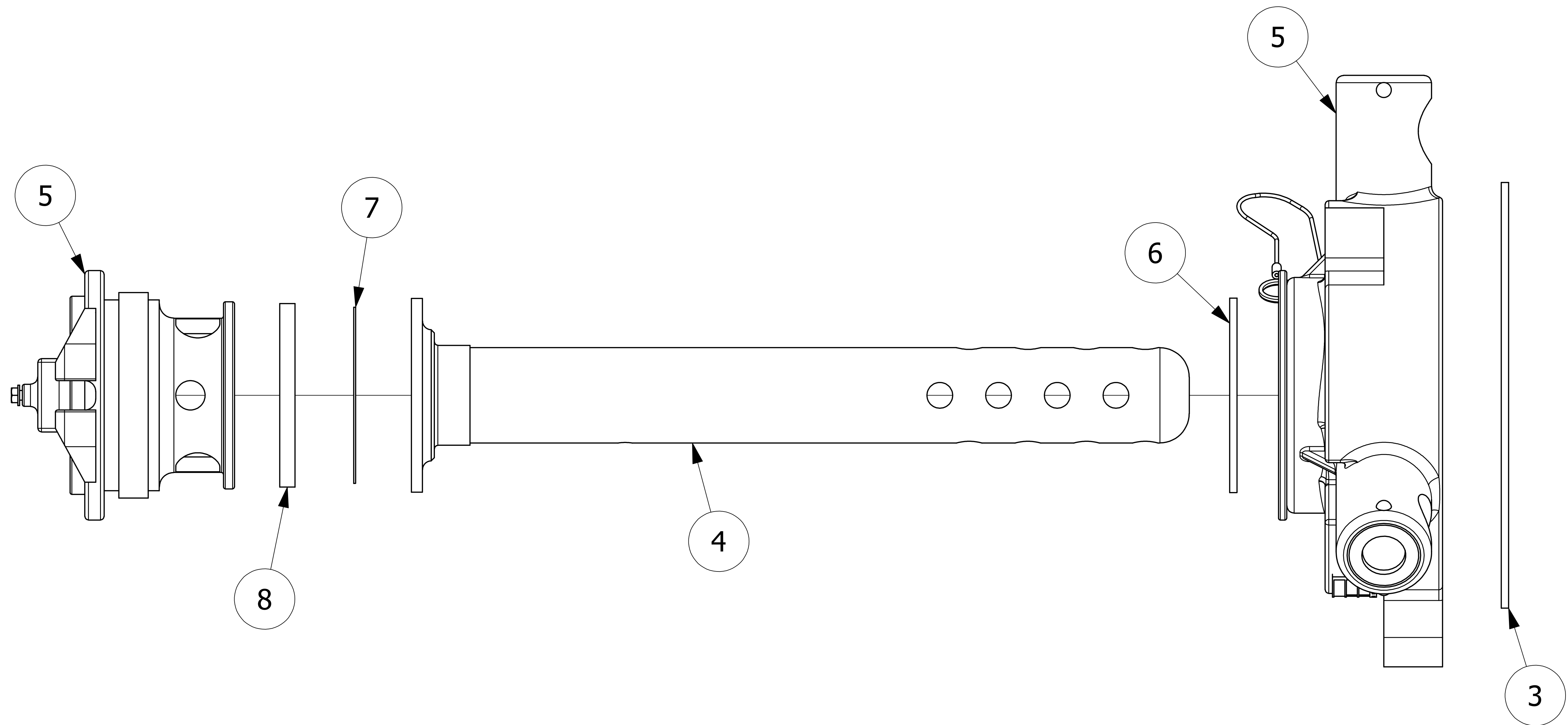

- NOTES:
1. CUSTOMERS RESPONSIBILITY FOR COMPATIBILITY OF COMMODITY.
 2. AAR APPROVAL # PRD-162102.
 3. SEE DOCUMENT QAP5A-1 FOR MARKING PROCEDURE.
 4. FASTEN ID PLATE WITH DRIVE SCREWS.

REV	BY	DATE	DESCRIPTION
D	JG	2-7-17	AAR APPROVAL # WAS SRD-063000
C	TAK	9-4-13	ADDED A15152, DR218 & QAP5A-1 NOTE
B	AJB	12-28-06	CHANGED AAR APPROVAL NO.
A	CHL	1-12-05	NEW PART ADDED TO SYSTEM

UNLESS OTHERWISE SPECIFIED DIMENSIONAL TOLERANCES FRACTIONAL: ±1/16 X.XX: ±.03 X.XXX: ±.015 ANGULAR: ±1° DEBURR ALL SHARP EDGES. ALL MACHINED SURFACES TO HAVE A 125 RMS FINISH UNLESS NOTED OTHERWISE.	DRAWN BY: CHL
THIRD ANGLE PROJECTION	CHECKED BY: ACC
	PROTOTYPE BY: CHL
	PROTOTYPE DATE: 6/11/2004
	APPROVED FOR PRODUCTION BY: ACC
	PRODUCTION DATE: 1/12/2005

SALCO PRODUCTS, INC.

QUICK INSPECT SAFETY VENT

MATERIAL: **SEE BOM**

PROJECT #: **030708** SHEET #: **1 OF 1** SCALE: **1:1**

DRAWING #: **E19294** PART #: **QI261HSP12A**