

| NO | PART NAME | PART# | REQ'D | MATERIAL |
|----|--------------------------------|----------|-------|---------------|
| 1 | ID PLATE 3" X 3/4" | A15152 | .5 | ALUMINUM |
| 2 | DRIVE SCREW TYPE U #2 X 1/8" | DR218 | 2 | 18-8 SS |
| 3 | QUICK INSPECT FLANGE GASKET | FG5507 | 1 | BLACK VITON B |
| 4 | QUICK INSPECT SAFETY VENT | QI261BSA | 1 | BLACK NORYL |
| 5 | QI RETAINER GASKET | QI261G7 | 1 | BLACK VITON B |
| 6 | RUPTURE DISC (SOLD SEPARATELY) | | | |

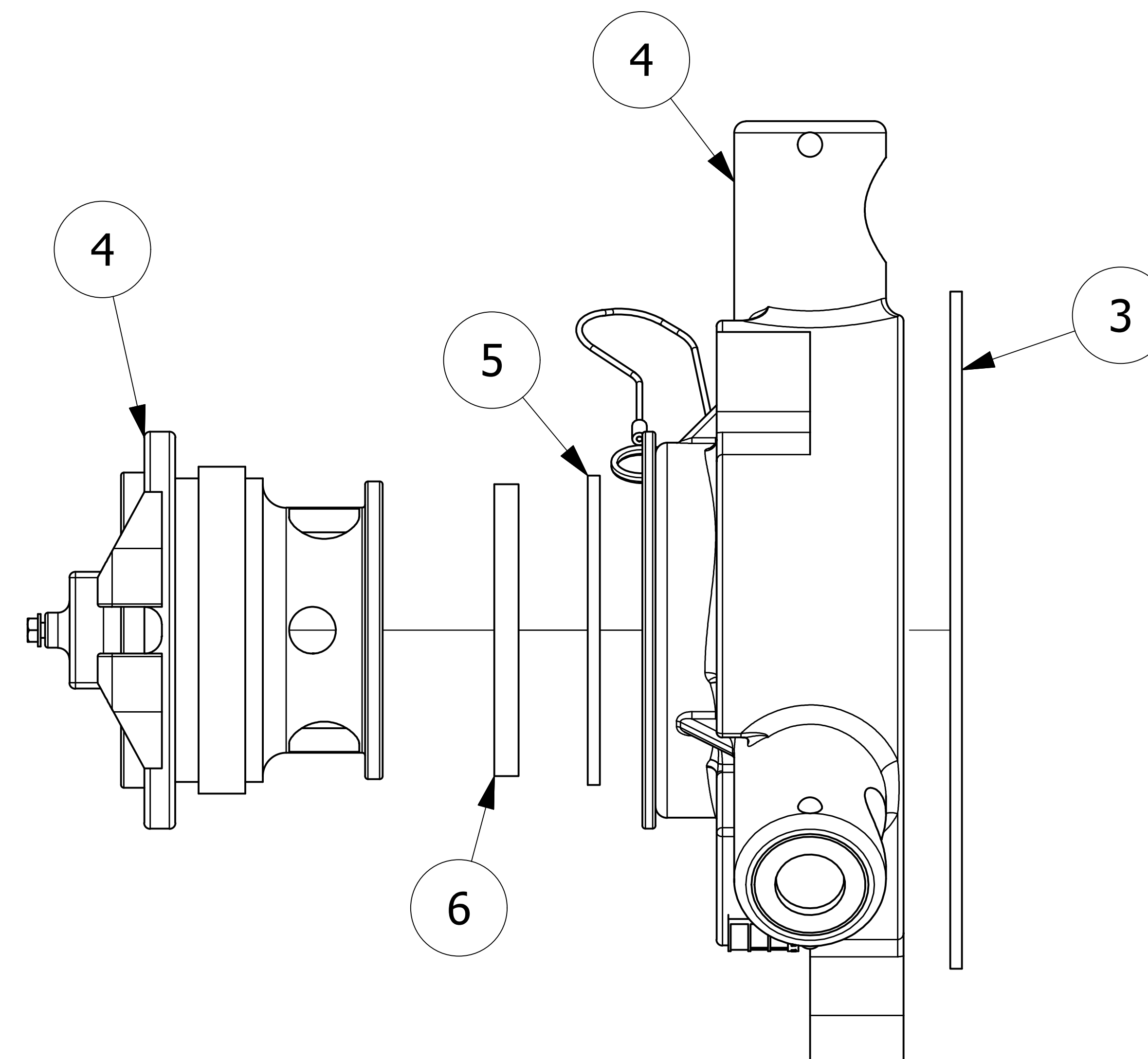

- NOTES:
1. CUSTOMERS RESPONSIBILITY FOR COMPATIBILITY OF COMMODITY.
 2. AAR APPROVAL # PRD-162102.
 3. SEE DOCUMENT Q-2.14 FOR MARKING PROCEDURE.
 4. FASTEN ID PLATE WITH DRIVE SCREWS.

| REV | BY | DATE | DESCRIPTION |
|-----|-----|----------|------------------------------------|
| E | CHL | 10/31/19 | CHANGED NOTE QAP5A-1 TO Q-2.14 |
| D | JG | 2/8/17 | AAR APPROVAL # WAS SRD-063000 |
| C | TAK | 9/16/13 | ADDED A15152, DR218 & QAP5A-1 NOTE |
| B | AJB | 12/28/06 | CHANGED AAR APPROVAL NO. |
| A | PJG | 6/1/04 | NEW PART ADDED TO SYSTEM |

| | | |
|--------------------------------------------------------------------------------------------------------------------------------------------------------------------------------------------------------------------------------------------------------------|-----------------------------|----------|
| UNLESS OTHERWISE SPECIFIED DIMENSIONAL TOLERANCES FRACTIONAL: ±1/16 X.XX: ±.03 X.XXX: ±.015 ANGULAR: ±1° DEBURR ALL SHARP EDGES. ALL MACHINED SURFACES TO HAVE A 125 RMS FINISH UNLESS NOTED OTHERWISE. THIRD ANGLE PROJECTION | DRAWN BY: | PJG |
| | CHECKED BY: | ACC |
| | PROTOTYPE DATE: | 6/1/2004 |
| | APPROVED FOR PRODUCTION BY: | ACC |
| | PRODUCTION DATE: | 6/1/2004 |
| | SIZE: | E |
| DRAWING #: | 19260 | |

SALCO PRODUCTS, INC.

QUICK INSPECT SAFETY VENT

SEE BOM

PROJECT #: **WAG0144** SHEET #: **1 OF 1** SCALE: **1 : 1**

PART #: **QI261NSPR7A**