

SALES DRAWING

SALES DRAWING

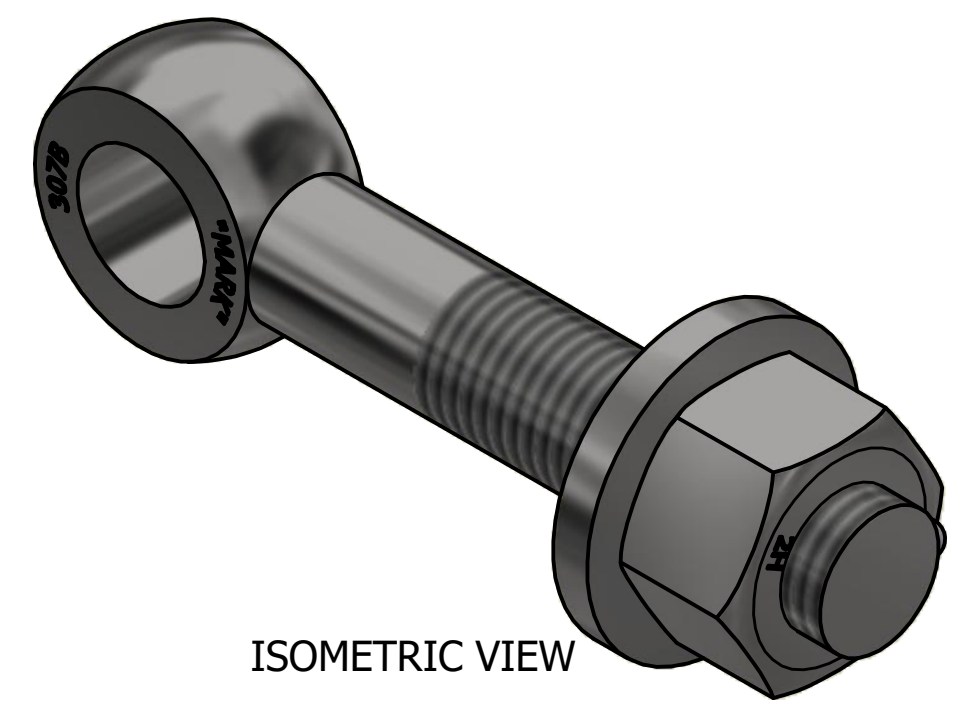
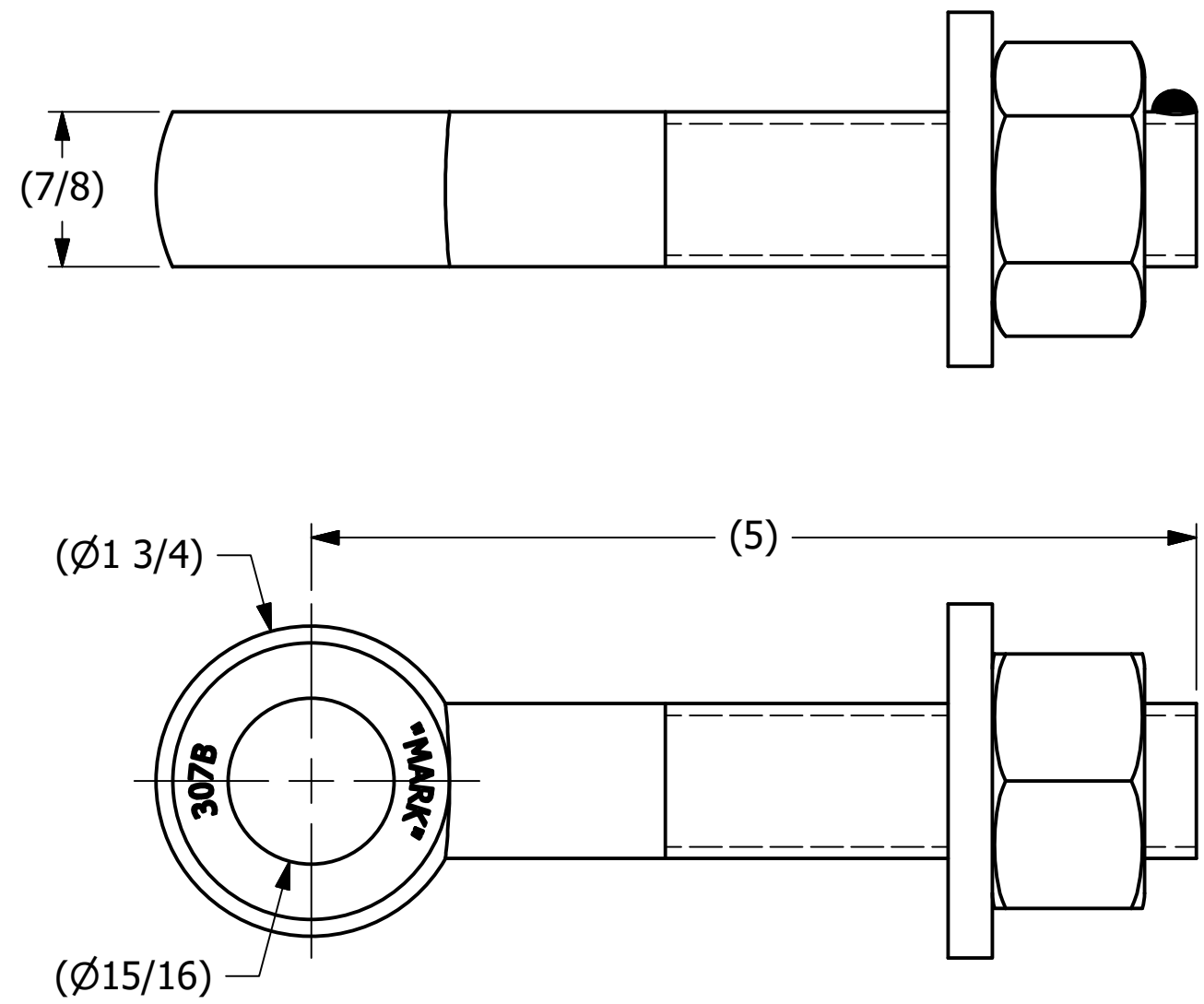

ISOMETRIC VIEW

REV	BY	DATE	DESCRIPTION
C	JJK	4-16-14	UPDATED EYEBOLT OD
B	CHL	6-10-02	CHANGED MATERIAL WASH78T WAS CS Z/P
A	FOD	8-5-99	UPDATED BOM, ITEM #1 WAS EB785

<small>UNLESS OTHERWISE SPECIFIED DIMENSIONAL TOLERANCES</small> FRACTIONAL: ±1/16 X.XX: ±.03 X.XXX: ±.015 ANGULAR: ±1° <small>DEBURR ALL SHARP EDGES. ALL MACHINED SURFACES TO HAVE A 125 RMS FINISH UNLESS NOTED OTHERWISE.</small>	DRAWN BY:	FOD
	CHECKED BY:	SAB
	PROTOTYPE BY:	FOD
	PROTOTYPE DATE:	5/27/1999
<small>THIRD ANGLE PROJECTION</small> 	APPROVED FOR PRODUCTION BY:	SAB
	PRODUCTION DATE:	5/27/1999

PART NAME: EYEBOLT ASSEMBLY 7/8"X5"		
MATERIAL: CARBON STEEL		
PROJECT #:	SHEET #: 1 OF 1	SCALE: 1:1
DRAWING #: B13494	PART #: EB785XA	

THIS PRINT, PROPERTY OF SALCO PRODUCTS INC., CONTAINS PROPRIETARY INFORMATION AND MUST NOT BE COPIED, REPRODUCED, OR USED DETRIMENTALLY TO OUR INTEREST.