

NO.	PART NAME	PART #	REQ'D	MATERIAL
1	EYEBOLT 7/8"X6 1/2"	EBR7865HFTS6R	1	316 SS
2	EYEBOLT SAFETY COLLAR 7/8"	COLLAR78S3T3	1	303 SS
3	HEAVY SQUARE NUT 7/8"-9	N78S6	1	416 SS
4	FLAT WASHER 7/8"	WASH78S4T	1	304 SS
5	HUCK RIVET 1/4"X13/16"	A16204	1	304 SS

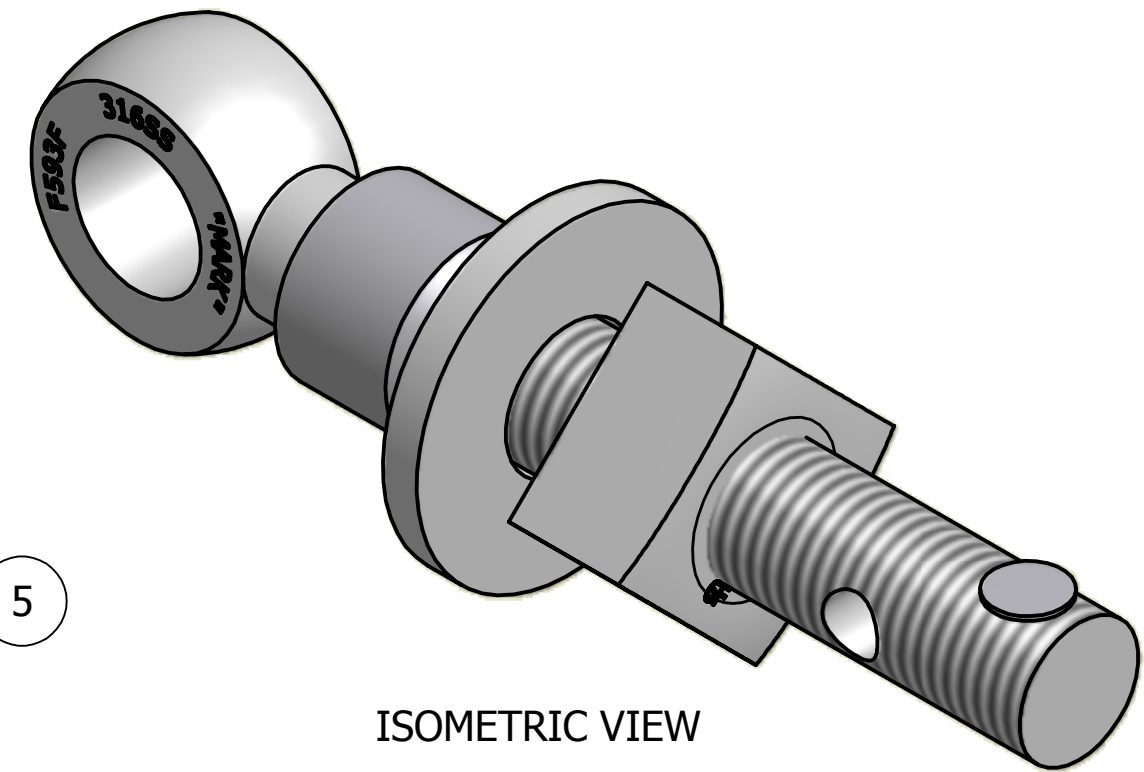

ISOMETRIC VIEW

NOTE:
 APPLY JET LUBE (PFPE GREASE) TO WORKING THREAD AREA,
 THE BOTTOM FACE OF THE NUT AND THE TOP FACE OF THE
 WASHER.

UNLESS OTHERWISE SPECIFIED DIMENSIONAL TOLERANCES	DRAWN BY:	CHL
FRACTIONAL: ±1/16	CHECKED BY:	VD
X.XX: ±.03	PROTOTYPE BY:	CHL
X.XXX: ±.015	PROTOTYPE DATE:	4/27/2010
ANGULAR: ±1°	APPROVED FOR PRODUCTION BY:	VD
THIS PRINT, PROPERTY OF SALCO PRODUCTS INC., CONTAINS PROPRIETARY INFORMATION AND MUST NOT BE COPIED, REPRODUCED, OR USED DETRIMENTALLY TO OUR INTEREST.	PRODUCTION DATE:	6/10/2010
THIRD ANGLE PROJECTION		

A	CHL	6-10-10	NEW PART ADDED TO SYSTEM
REV	BY	DATE	DESCRIPTION
SALCO PRODUCTS, INC.			
PART NAME: EYEBOLT ASSEMBLY 7/8"X6 1/2"			
MATERIAL: SEE BOM			
PROJECT #: WAG0784		SHEET #: 1 OF 1	SCALE: 1:1
DRAWING #: B28582		PART #: EB7865HFTAS6TC3L	