

NO	PART NAME	PART#	REQ'D	MATERIAL
1	HUCK RIVET 1/4"X13/16"	A16204	1	304 SS
2	EYEBOLT SAFETY CATCH 7/8"	DEB275SC	1	316 SS
3	EYEBOLT 7/8"X6"	EBR786HS6R	1	316 SS
4	HEAVY HEX NUT 7/8"-9	N78XS6	1	416 SS
5	FLAT WASHER 7/8" SAE	WASH78S6	1	316 SS

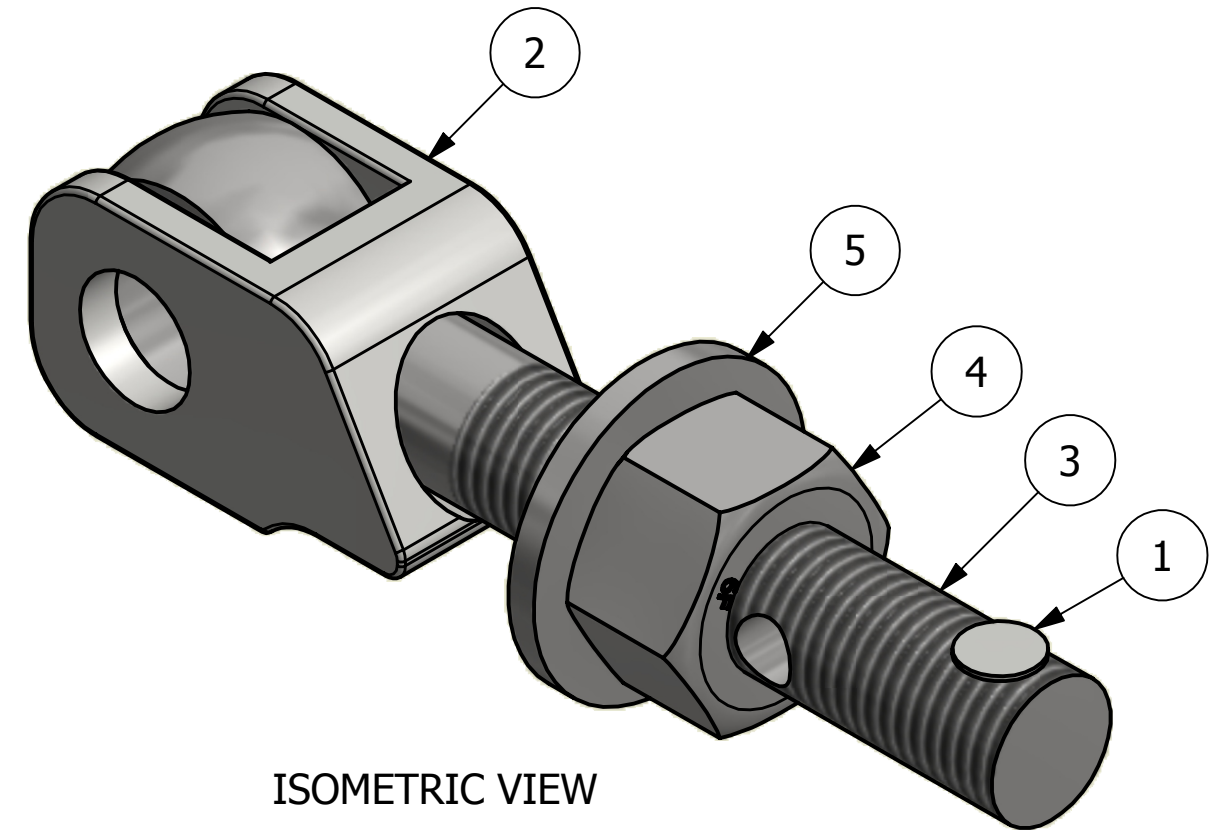

ISOMETRIC VIEW

REV	BY	DATE	DESCRIPTION
D	RJP	7-14-17	WASH78S6 WAS WASH78S4; UPDATED TO CURRENT STANDARDS
C	CHL	11-14-02	REPLACED SN78XS6 W/ N78XS6 & WASH78S4
B	CHL	11-26-01	REPLACED SN14S W/ A16204
A	FOD	8-5-99	UPDATED BOM ITEM #1 WAS EB786HS6R

UNLESS OTHERWISE SPECIFIED DIMENSIONAL TOLERANCES FRACTIONAL: ±1/16 X.XX: ±.03 X.XXX: ±.015 ANGULAR: ±1° DEBURR ALL SHARP EDGES. ALL MACHINED SURFACES TO HAVE A 125 RMS FINISH UNLESS NOTED OTHERWISE. THIRD ANGLE PROJECTION	DRAWN BY:	FOD
	CHECKED BY:	SAB
	PROTOTYPE BY:	FOD
	PROTOTYPE DATE:	6/8/1999
	APPROVED FOR PRODUCTION BY:	SAB
	PRODUCTION DATE:	6/8/1999

**SALCO PRODUCTS, INC.**

PART NAME: **EYEBOLT ASSEMBLY 7/8"X6"**

MATERIAL: **SEE BOM**

PROJECT #: \_\_\_\_\_ SHEET #: **1 OF 1** SCALE: **1:1**

DRAWING #: **B13518** PART #: **EB786XHAS6SC**

THIS PRINT, PROPERTY OF SALCO PRODUCTS INC., CONTAINS PROPRIETARY INFORMATION AND MUST NOT BE COPIED, REPRODUCED, OR USED DETRIMENTALLY TO OUR INTEREST.