

NO.	PART NAME	PART #	REQ'D	MATERIAL
1	HEX JAM NUT 7/16"-20	N716S	1	18-8 SS
2	HEX LOCK NUT 5/16"-18	R20ANS	1	18-8 SS
3	TAMPER RESISTANT SCREW 10-32 X 3/8"	TRS1032SS	2	302 SS
4	VACUUM RELIEF VALVE GASKET 1 1/2"	VV1503G	1	BLACK EPDM SC
5	VACUUM RELIEF VALVE BUSHING 1 1/2"	VV15S41SB	1	303 SS
6	SPRING 3/4" X 3 5/16"	VV15S41SP	1	18-8 SS
7	VACUUM RELIEF VALVE STEM 1 1/2"	VVN15S4SA	1	304/18-8 SS
8	VACUUM RELIEF VALVE BODY ASSEMBLY 1 1/2"	VVN15S4VBA	1	304 SS
9	VACUUM RELIEF VALVE CAP	VVNS4TC	1	304 SS

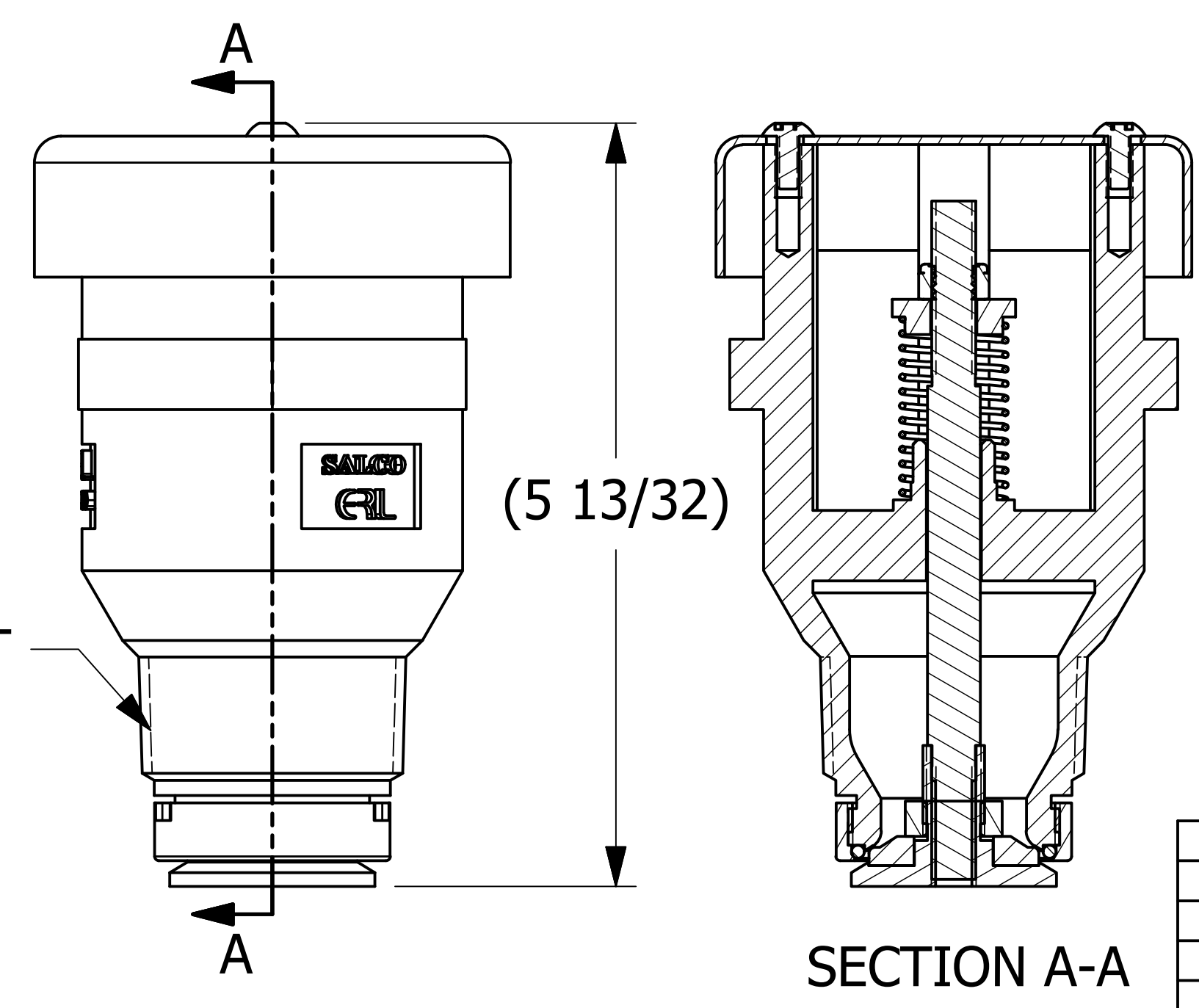

- NOTES:**
1. VALVE BODY IS 304 SS WITH TEFLON ENCAPSULATED SILICONE O-RING.
  2. VACUUM RATING IS 1.53" OF Hg (-.75 PSI) PER APPENDIX A, SECTION 4.10 OF AAR TANK CAR MANUAL.
  3. AAR APPROVAL # E-202141.
  4. TEST PER Q-2.15.7.
  5. SEE DOCUMENT Q-2.14 FOR MARKING PROCEDURE.
  6. VV1503G IS SULFUR-CURED.

L	WEB	7/20/21	UPDATED MARKINGS; REMOVED LABEL
K	WEB	9/4/20	AAR # WAS E-099034; UPDATED TITLE BLOCK
J	JG	3/20/18	Q-2.14 WAS QAP5A-1; Q-2.15.7 WAS QAP4C-1
I	RJP	7/23/14	TRS1032SS WAS BHCS73742
H	WEB	1/30/14	CHANGED "VVN15" TO PART NUMBER
G	RJP	1/9/14	UPDATED TITLE BLOCK
F	GS	11/26/12	ADDED MARK PER QAP5A-1 NOTE & TITLE BLOCK ADDED TEXT SIZE & "EPDM" MARKING TO CAP
E	TAJ	8/28/12	ADDED SERIAL # NOTE
D	BG	7/12/12	UPDATED VVN15S4VBA & REPLACED BHCS1034S W/BHCS73742
C	CHL	1/29/10	AAR APPROVAL # WAS E-999001
B	WRB	9/12/08	REMOVED WASH316S AND WASH716S, ADDED NOTES, CORRECTED BOM ERRORS AND UPDATED 3D STANDARDS
A	ACC	3/28/05	ADDED PART INTO THE SYSTEM
REV	BY	DATE	DESCRIPTION

UNLESS OTHERWISE SPECIFIED DIMENSIONAL TOLERANCES	DRAWN BY:	ACC
FRACTIONAL: ±1/16	CHECKED BY:	AVD
X.XX: ±.03	PROTOTYPE DATE:	3/28/2005
X.XXX: ±.015	APPROVED FOR PRODUCTION BY:	ACC
ANGULAR: ±1°	PRODUCTION DATE:	3/28/2005
DEBURR ALL SHARP EDGES. ALL MACHINED SURFACES TO HAVE A 125 RMS FINISH. UNLESS NOTED OTHERWISE. THIRD ANGLE PROJECTION	SIZE:	D
	DRAWING #:	20354

**SALCO PRODUCTS, INC.**

PART NAME: **VACUUM RELIEF VALVE 1 1/2" THREADED**

MATERIAL: **SEE BOM**

PROJECT #: **970312** SHEET #: **1 OF 1** SCALE: **1:1**

PART #: **VVN15S4103A**