

NO	PART NAME	PART #	REQ'D	MATERIAL
1	ID PLATE 3" X 3/4"	A15152	.5	ALUMINUM
2	DRIVE SCREW TYPE U #2 X 1/8"	DR218	2	18-8 SS
3	SURGE PROTECTOR	DSP3313	1	NORYL
4	QUICK INSPECT FLANGE GASKET	FG5507	1	BLACK VITON B
5	QUICK INSPECT SAFETY VENT	QI261BSA	1	BLACK NORYL
6	QI RETAINER GASKET	QI261G7	1	BLACK VITON B
7	QI RUPTURE DISK GASKET	QI261RDG7	1	BLACK VITON B
8	RUPTURE DISC (SOLD SEPARATELY)			

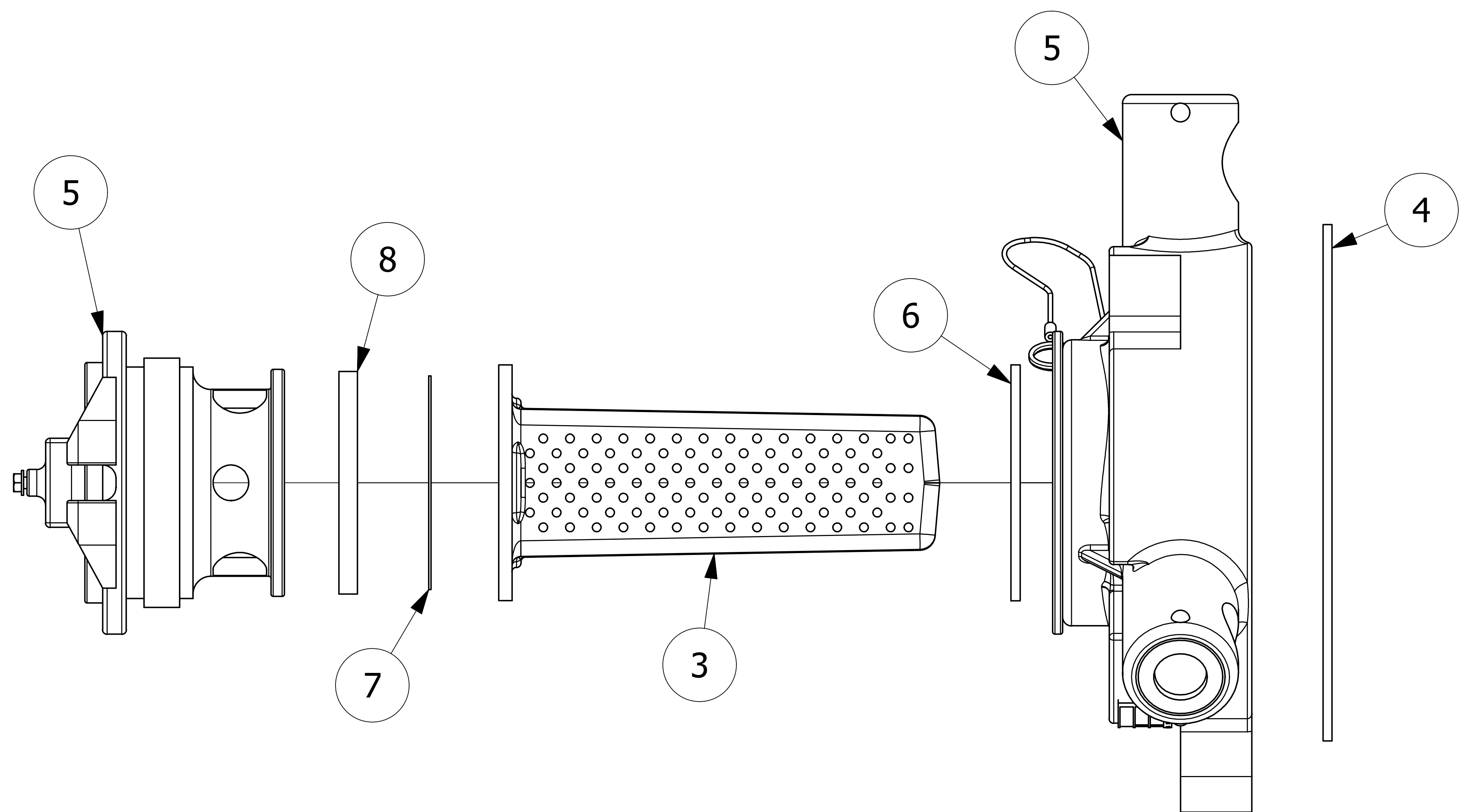

- NOTES:**
1. CUSTOMERS RESPONSIBILITY FOR COMPATIBILITY OF COMMODITY.
 2. AAR APPROVAL # PRD-162102.
 3. SEE DOCUMENT Q-2.14 FOR MARKING PROCEDURE.
 4. FASTEN ID PLATE WITH DRIVE SCREWS.

D	CHL	2/14/22	Q-2.14 WAS QAP5A-1
C	JG	2/7/17	AAR APPROVAL # WAS SRD-063000
B	TAK	8/28/13	ADDED A15152, DR218 & QAP5A-1 NOTE
A	CHL	1/3/08	NEW PART ADDED TO SYSTEM
REV	BY	DATE	DESCRIPTION

UNLESS OTHERWISE SPECIFIED DIMENSIONAL TOLERANCES FRACTIONAL: ±1/16 X.XX: ±.03 X.XXX: ±.015 ANGULAR: ±1° DEBURR ALL SHARP EDGES. ALL MACHINED SURFACES TO HAVE A 125 RMS FINISH UNLESS NOTED OTHERWISE. THIRD ANGLE PROJECTION	DRAWN BY:	CHL
	CHECKED BY:	PJG
	PROTOTYPE DATE:	5/9/2007
	APPROVED FOR PRODUCTION BY:	PJG
	PRODUCTION DATE:	1/3/2008
	SIZE:	E
	DRAWING #:	23540

SALCO PRODUCTS, INC.

QUICK INSPECT SAFETY VENT

SEE BOM

PROJECT #: **WAG0423** SHEET #: **1 OF 1** SCALE: **1 : 1**

PART #: **QI2617A**