

NO	PART NAME	PART#	REQ'D	MATERIAL
1	ID PLATE 3" X 3/4"	A15152	.5	ALUMINUM
2	DRIVE SCREW TYPE U #2 X 1/8"	DR218	2	18-8 SS
3	SURGE PROTECTOR	DSP3313R	1	RYTON
4	QUICK INSPECT FLANGE GASKET	FG550E	1	BLACK EPDM SC
5	QUICK INSPECT SAFETY VENT	QI261BSA	1	BLACK NORYL
6	QI RETAINER GASKET	QI261G3	1	BLACK EPDM SC
7	QI RUPTURE DISK GASKET	QI261RDG3	1	BLACK EPDM SC
8	RUPTURE DISC (SOLD SEPARATELY)			

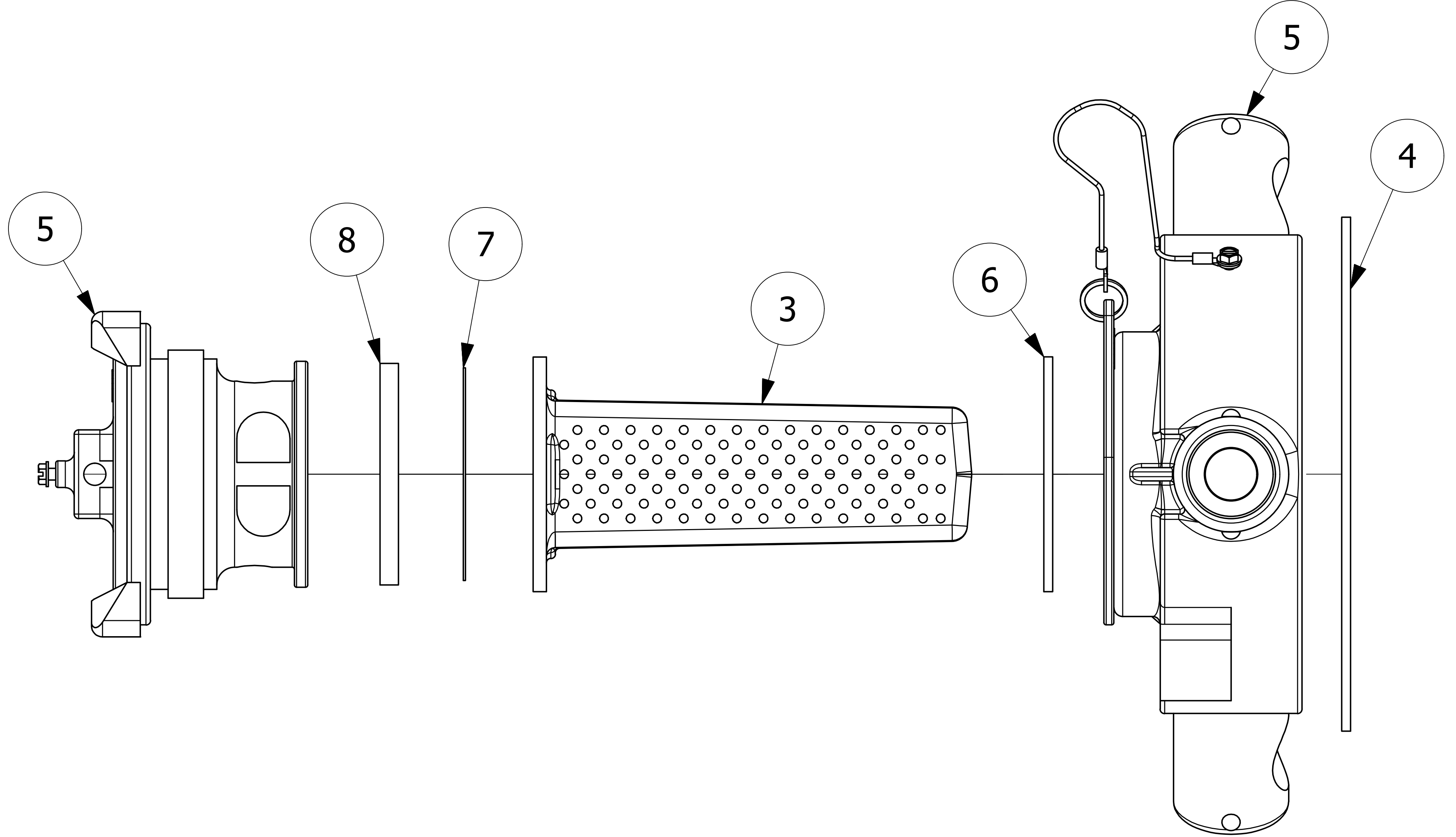

- NOTES:**
1. CUSTOMERS RESPONSIBILITY FOR COMPATIBILITY OF COMMODITY.
 2. AAR APPROVAL # PRD-162102.
 3. SEE DOCUMENT Q-2.14 FOR MARKING PROCEDURE.
 4. FASTEN ID PLATE WITH DRIVE SCREWS.

D	WEB	6/1/20	Q-2.14 WAS QAP5A-1; UPDATED TITLE BLOCK
C	JG	2/8/17	AAR APPROVAL # WAS SRD-063000
B	TAK	9/16/13	ADDED A15152, DR218 & QAP5A-1 NOTE
A	AJB	12/28/06	CHANGED AAR APPROVAL NO.
REV	BY	DATE	DESCRIPTION

UNLESS OTHERWISE SPECIFIED DIMENSIONAL TOLERANCES FRACTIONAL: ±1/16 X.XX: ±.03 X.XXX: ±.015 ANGULAR: ±1° DEBURR ALL SHARP EDGES. ALL MACHINED SURFACES TO HAVE A 125 RMS FINISH UNLESS NOTED OTHERWISE. THIRD ANGLE PROJECTION	DRAWN BY: ACC	CHECKED BY: PJG	PROTOTYPE DATE: 2/9/1998	APPROVED FOR PRODUCTION BY: CLH	PRODUCTION DATE: 2/9/1998	SIZE: E	DRAWING #: 16067
--	---------------	-----------------	--------------------------	---------------------------------	---------------------------	---------	------------------

SALCO PRODUCTS, INC.

QUICK INSPECT SAFETY VENT

SEE BOM

PROJECT #: 010814 SHEET #: 1 OF 1 SCALE: 1 : 1

PART #: **QI261R3A**