

NO	PART NAME	PART #	REQ'D	MATERIAL
1	HUCK RIVET 1/4"X13/16"	A16204	1	304 SS
2	EYEBOLT 7/8"X6"	EBR786RT	1	CS/PTFE
3	HEAVY HEX NUT 7/8"-9	N78XT	1	CS/PTFE
4	FLAT WASHER 7/8"	WASH78TEF	1	CS/PTFE

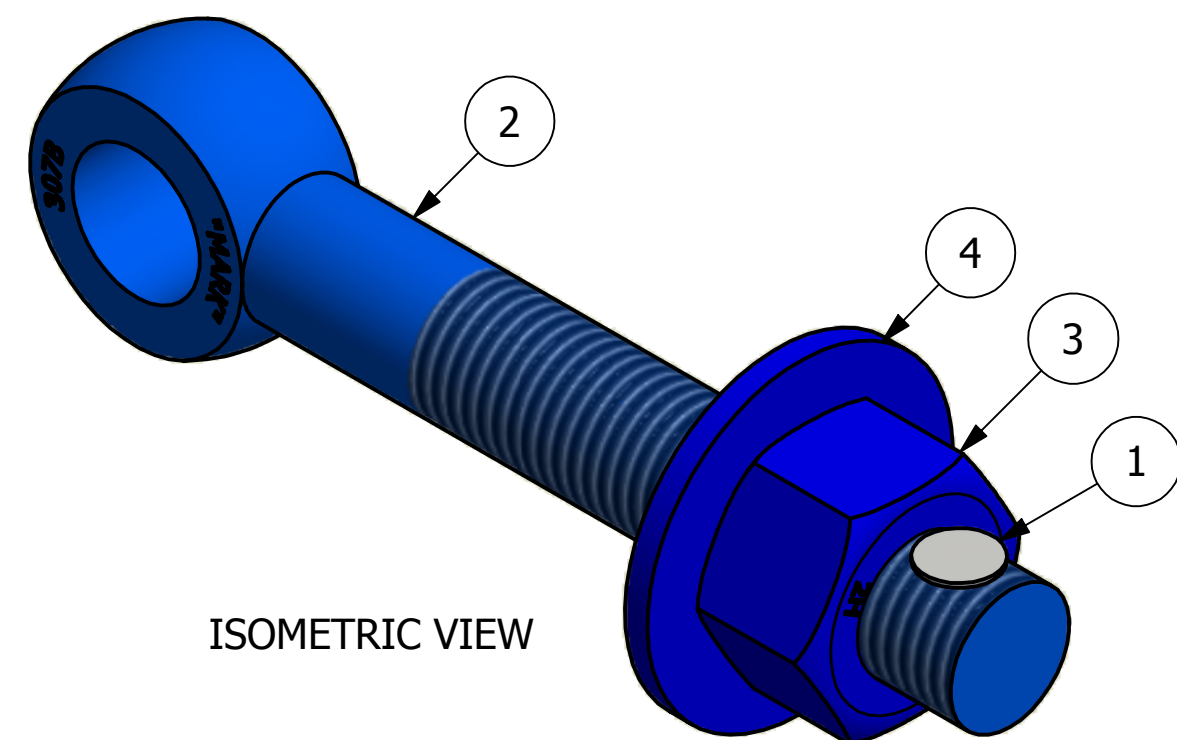

ISOMETRIC VIEW

NOTE:
PARTS TO BE PTFE COATED PRIOR TO ASSEMBLY.

REV	BY	DATE	DESCRIPTION
B	RJP	4-12-17	CHANGED 'TEFLON' TO 'PTFE'
A	KHK	8-19-13	RELEASED FOR PRODUCTION

<small>UNLESS OTHERWISE SPECIFIED DIMENSIONAL TOLERANCES</small> FRACTIONAL: ±1/16 X.XX: ±.03 X.XXX: ±.015 ANGULAR: ±1° <small>DEBURR ALL SHARP EDGES. ALL MACHINED SURFACES TO HAVE A 125 RMS FINISH UNLESS NOTED OTHERWISE.</small>	DRAWN BY:	KHK
	CHECKED BY:	CHL
	PROTOTYPE BY:	KHK
	PROTOTYPE DATE:	6/19/2013
	APPROVED FOR PRODUCTION BY:	WRB
	PRODUCTION DATE:	8/19/2013

SALCO PRODUCTS, INC.

PART NAME: **EYEBOLT ASSEMBLY 7/8"X6"**

MATERIAL: **SEE BOM**

PROJECT #: **130618FR1** SHEET #: **1 OF 1** SCALE: **1:1**

DRAWING #: **B36561** PART #: **EB786XAT**

THIS PRINT, PROPERTY OF SALCO PRODUCTS INC., CONTAINS PROPRIETARY INFORMATION AND MUST NOT BE COPIED, REPRODUCED, OR USED DETRIMENTALLY TO OUR INTEREST.