

NO	PART NAME	PART#	REQ'D	MATERIAL
1	LOCK RING	B13922	1	304 SS
2	BALL VALVE 2" THREADED	CA76F-108-24-SP1	1	316 SS
3	HEX LOCK NUT 3/8"-16	EA111N	1	CS Z/P
4	PIPE NIPPLE 2"	FA0464317	1	304 SS
5	FLAT WASHER 3/8" USS	KL103FW	2	CS Z/P
6	S-HOOK 3/8"X3 1/2"	SC38SH	1	CS Z/P
7	CHAIN LINK 3/8"	SC43	16	CS
8	PLUG ASSEMBLY 2"	TC2N60P1A	1	NITRONIC 60 / CS
9	BOTTOM OUTLET CAP 4"	TC4BCDI	1	DUCTILE IRON
10	HEX BOLT 3/8"-16X2 1/4"	VPHC20B	1	CS Z/P

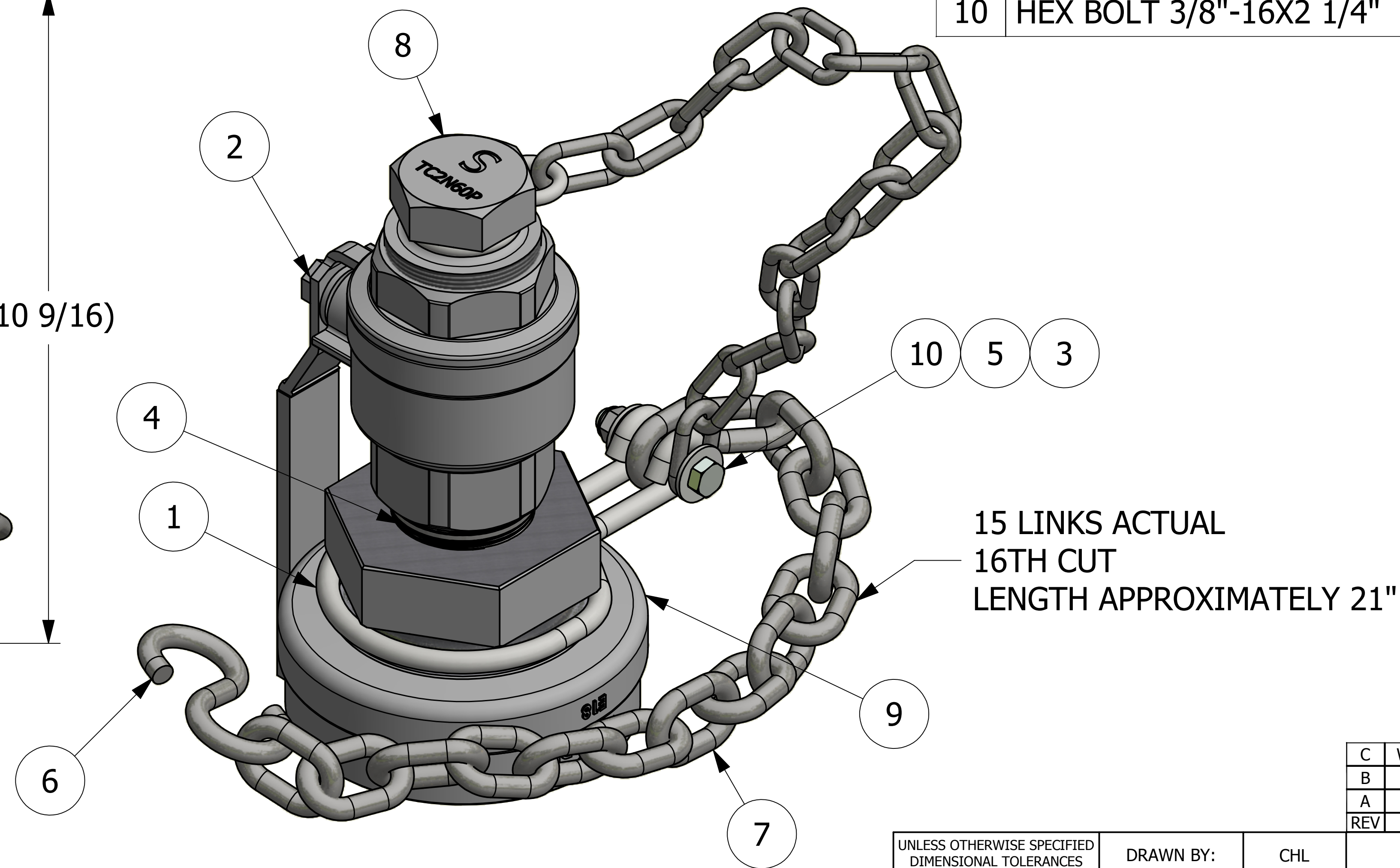
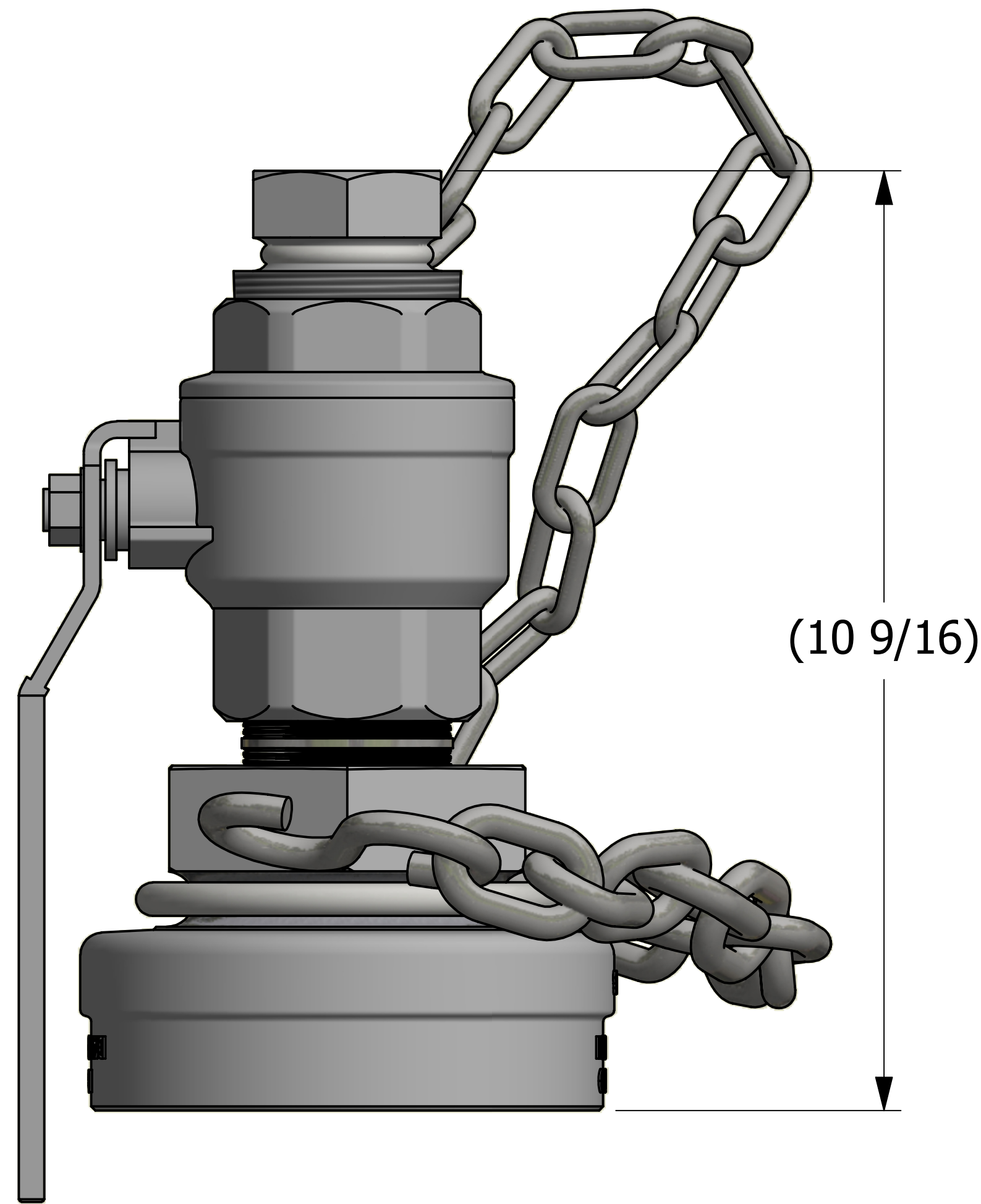

NOTE:
5 1/4"-4 UN-2B THREADS CONFORM TO ANSI B1.1 AND
FIGURE E18 FROM THE AAR TANK CAR MANUAL.

C	WEB	12-29-17	REPLACED N23S4 W/ FA0464317, HEIGHT WAS (11 9/16), SCALE WAS 1:1
B	RJP	3-18-15	CA76F-108-24-SP1 WAS 2BWEV6
A	JG	3-9-15	RELEASED FOR PRODUCTION
REV	BY	DATE	DESCRIPTION

UNLESS OTHERWISE SPECIFIED DIMENSIONAL TOLERANCES FRACTIONAL: ±1/16 X.XX: ±.03 X.XXX: ±.015 ANGULAR: ±1° DEBURR ALL SHARP EDGES. ALL MACHINED SURFACES TO HAVE A 125 RMS FINISH UNLESS NOTED OTHERWISE. THIRD ANGLE PROJECTION	DRAWN BY:	CHL
	CHECKED BY:	WRB
	PROTOTYPE BY:	CHL
	PROTOTYPE DATE:	2/23/2015
	APPROVED FOR PRODUCTION BY:	CHL
	PRODUCTION DATE:	3/9/2015

SALCO PRODUCTS, INC.

PART NAME: **BOTTOM OUTLET 4" CAP ASSEMBLY**

MATERIAL: **SEE BOM**

PROJECT #: **R150220** SHEET #: **1 OF 1** SCALE: **1:1**

DRAWING #: **D40931** PART #: **TC4BCDI2SS0A**