

NO.	PART NAME	PART#	REQ'D	MATERIAL
1	SPRING 21/32"X2"	A38818	1	18-8 SS
2	PIN 11/32" X 2"	A39986	1	304/316 SS
3	STICKER	A41924	1	VINYL
4	ANGLE IRON 1 1/4" X 1 1/4" X 1/4"	B31012	2	CS
5	ANGLE 3" X 3" X 3/8"	B39133	1	CS
6	BOV ADAPTER MCKENZIE	B39437	1	CS
7	LOCKING BRACKET	B39444	1	304 SS
8	HANDLE EXTENSION ASSEMBLY	BOVHELCS03	1	CS/SS
9	SAFEGUARD™ BOV DECAL	DBOV2224V02	1	VINYL
10	TAG	TAGSS3	1	304 SS

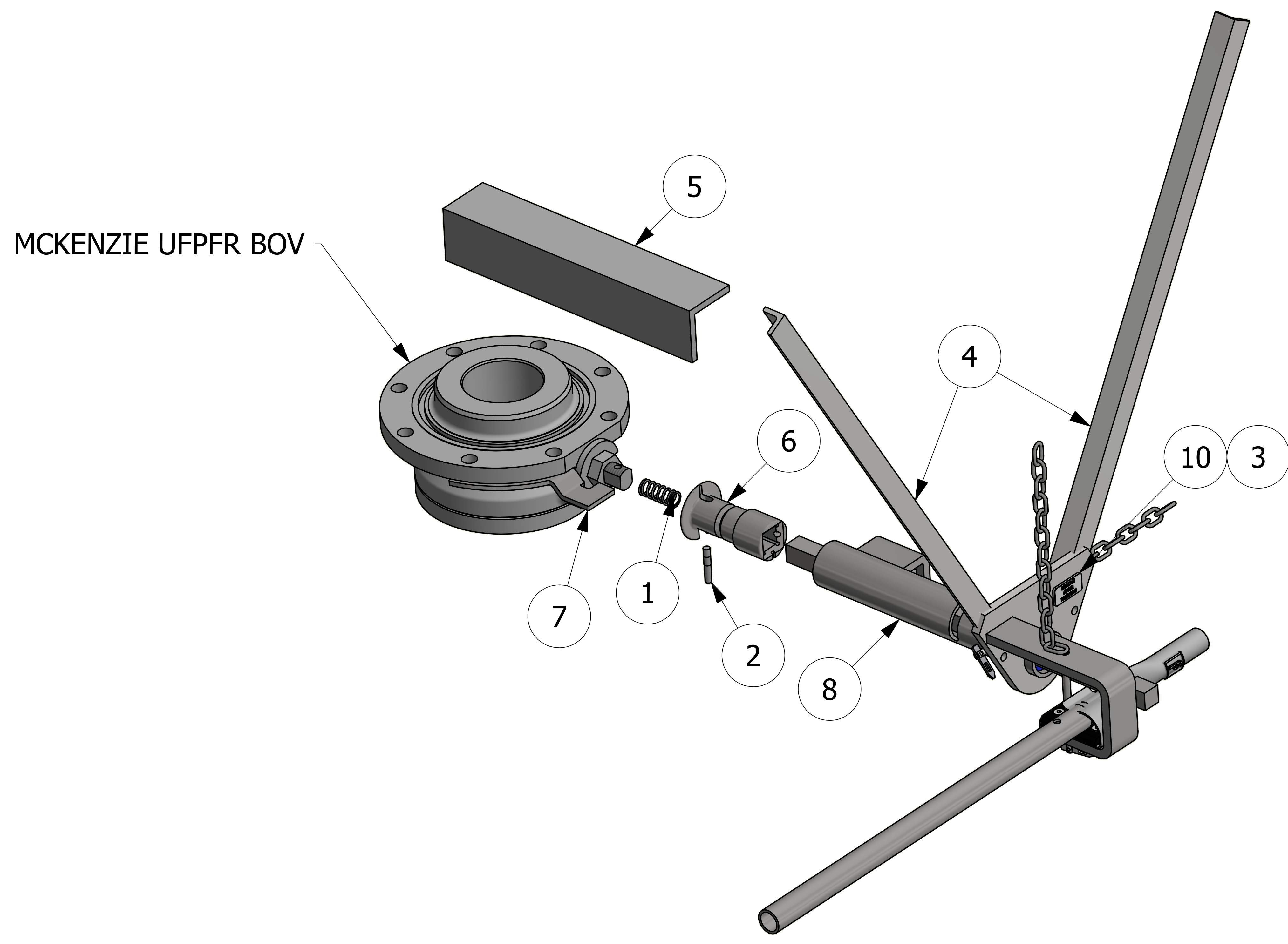
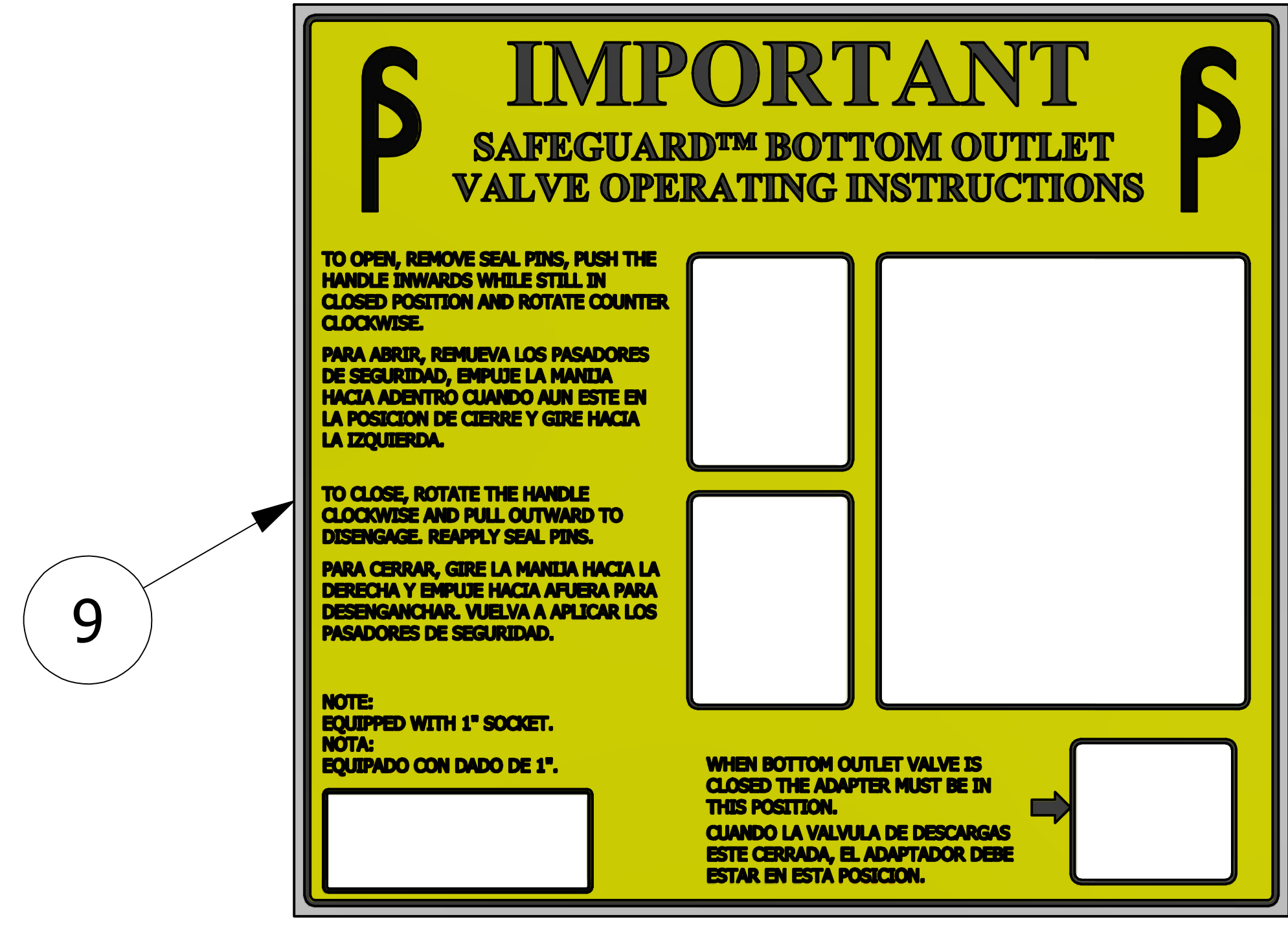

- NOTES:
1. VALVE SOLD SEPARATELY.
 2. WELDING OF BRACKETS WILL BE DONE UPON APPLICATION TO THE CAR IN ACCORDANCE WITH AWS D15.1.
 3. IF REQUIRED, CUSTOMER TO CUT MOUNTING BRACKETS TO LENGTH/ANGLE UPON APPLICATION TO THE CAR.
 4. ENGRAVE TAGSS3 WITH "SAFEGUARD™", "MCK03", AND DATE "***/**" (MONTH/YEAR). TEXT HEIGHT 1/4" MIN.
 5. WELD TAGSS3 PER DSS 12 WELDING SPECIFICATIONS.
 6. APPLY A41924 TO TAGSS3 AFTER IT HAS BEEN WELDED ON.
 7. PATENT PENDING.

REV	BY	DATE	DESCRIPTION
D	WEB	4-6-18	ADDED TAG PLACEMENT DIMENSIONS, ADDED 1/8 TO TAG WELD, SORTED BOM, UPDATED WELD NOTES
C	WEB	5-23-17	ADDED NOTE TO DETAIL D, ADDED "SAFEGUARD™" TO NOTE 5, UPDATED PART NAME, ADDED DSS 12 NOTE
B	WEB	11-13-15	REPLACED DBOV2224V01 WITH DBOV2224V02
A	JG	8-31-15	RELEASED FOR PRODUCTION

UNLESS OTHERWISE SPECIFIED DIMENSIONAL TOLERANCES FRACTIONAL: ±1/16	DRAWN BY:	RJP
X.XX: ±.03	CHECKED BY:	EJF
X.XXX: ±.015	PROTOTYPE BY:	RJP
ANGULAR: ±1°	PROTOTYPE DATE:	8/26/2015
DEBURR ALL SHARP EDGES. ALL MACHINED SURFACES TO HAVE A 125 RMS FINISH UNLESS NOTED OTHERWISE.	APPROVED FOR PRODUCTION BY:	VD
THIRD ANGLE PROJECTION	PRODUCTION DATE:	8/31/2015

SALCO PRODUCTS, INC.

PART NAME: **SAFEGUARD™ BOV OPERATING SYSTEM**

MATERIAL: **SEE BOM**

PROJECT #: **140114T** SHEET #: **1 OF 2** SCALE: **1:3**

DRAWING #: **E42194** PART #: **BOVHKITCSMCK03**

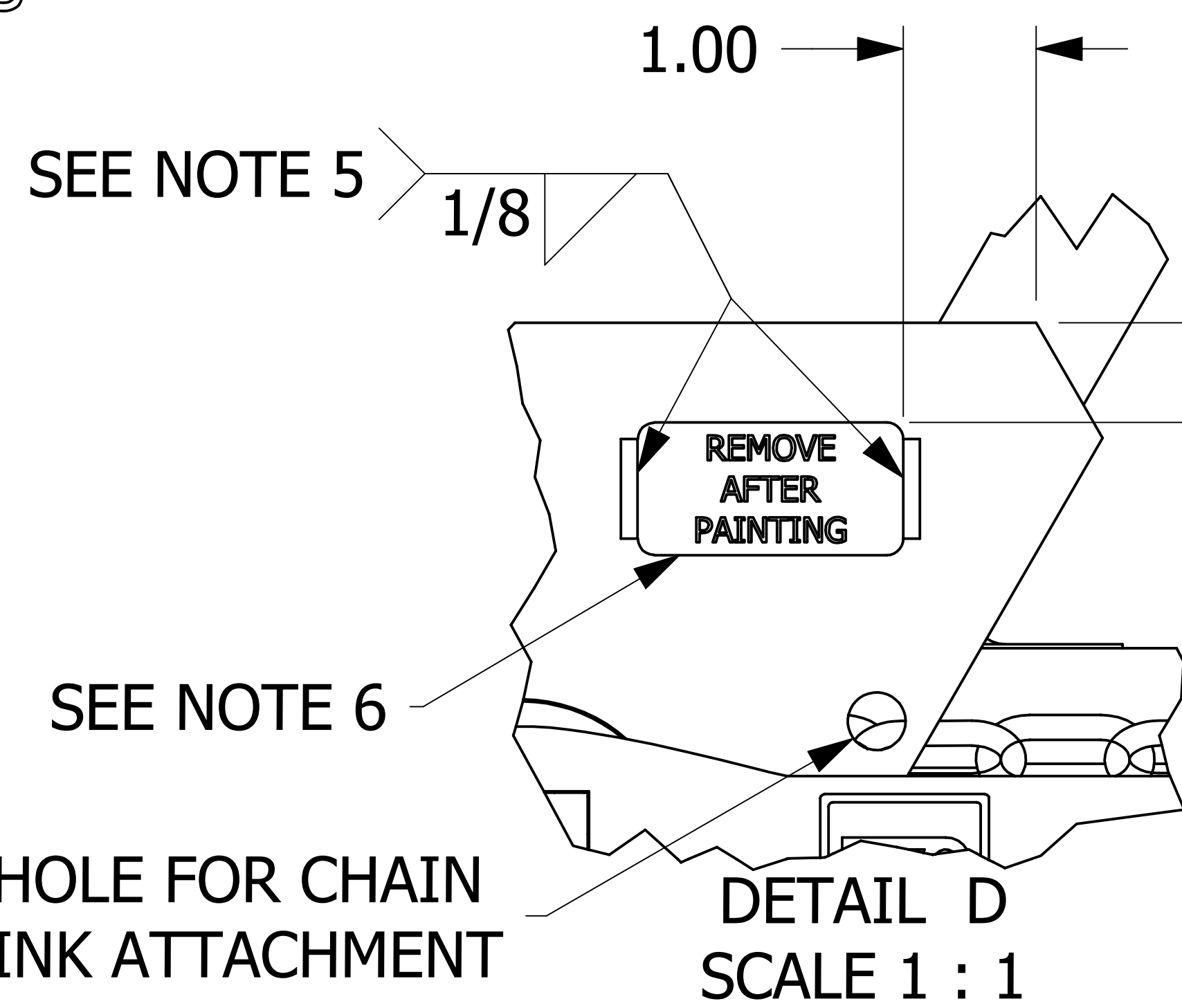
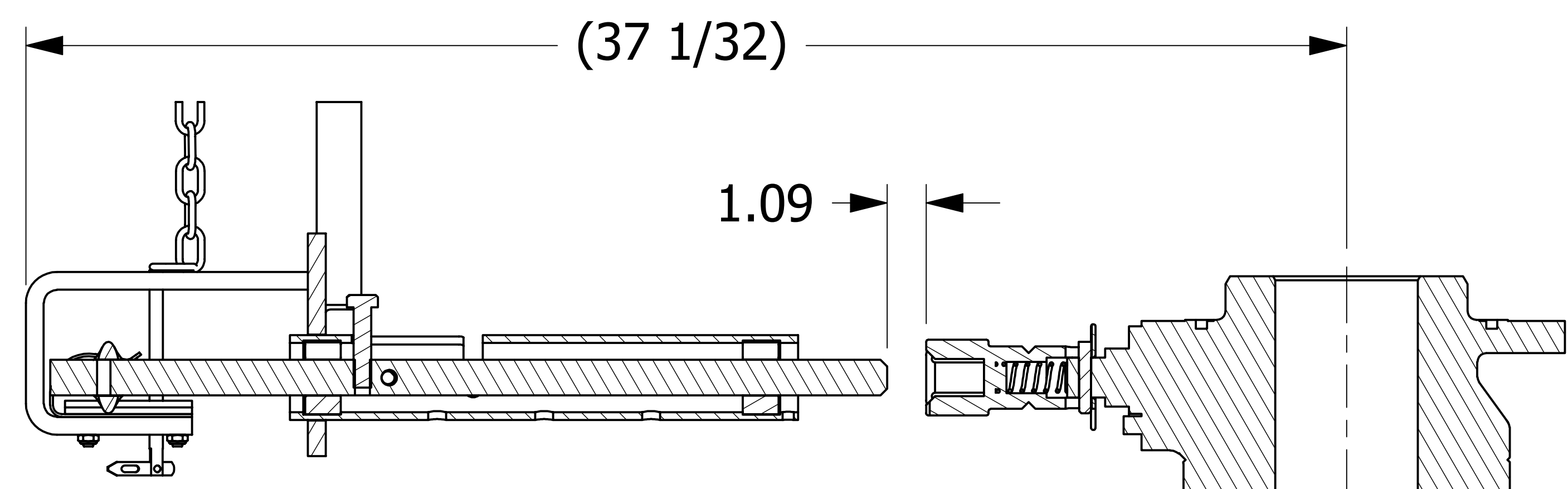
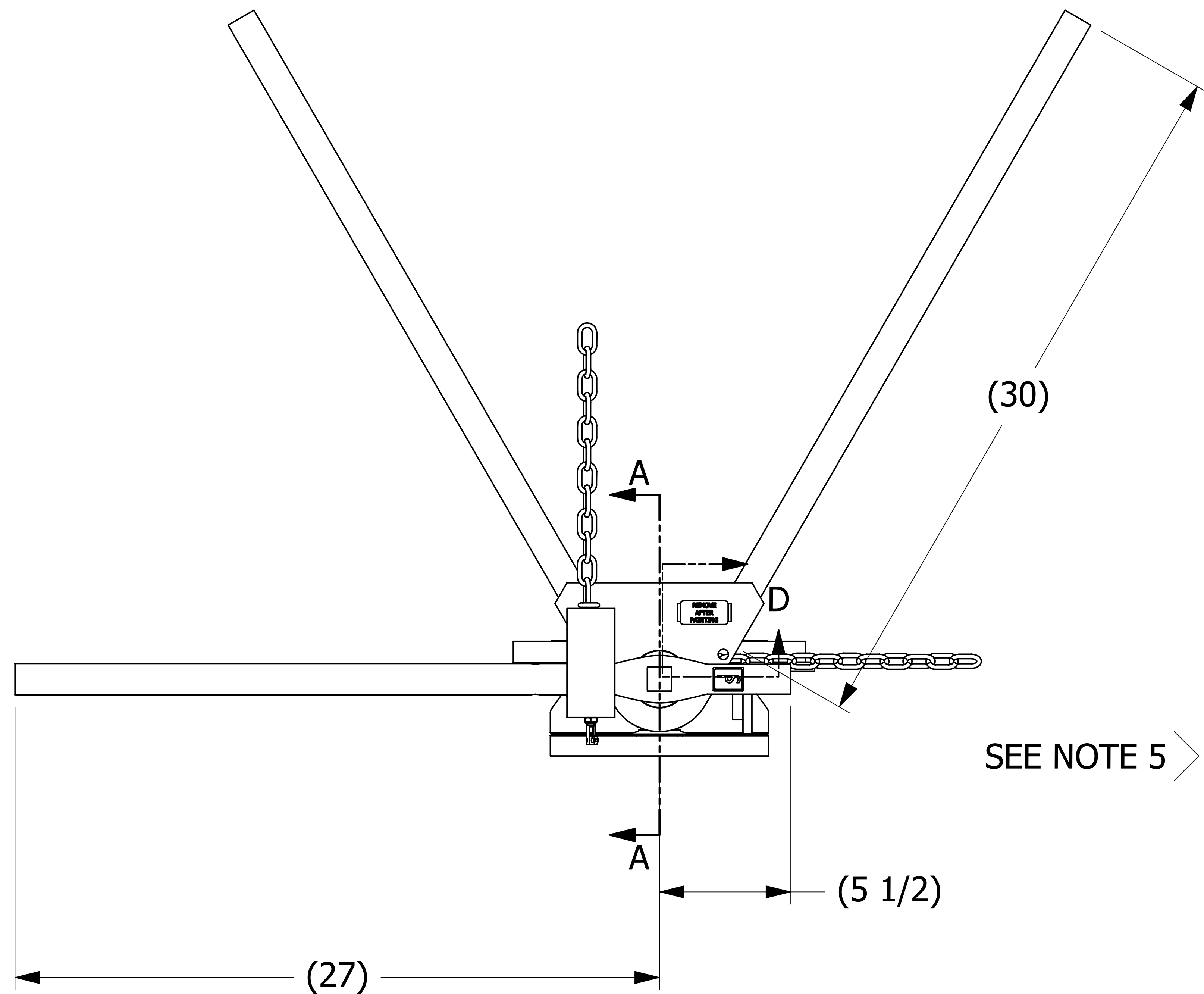
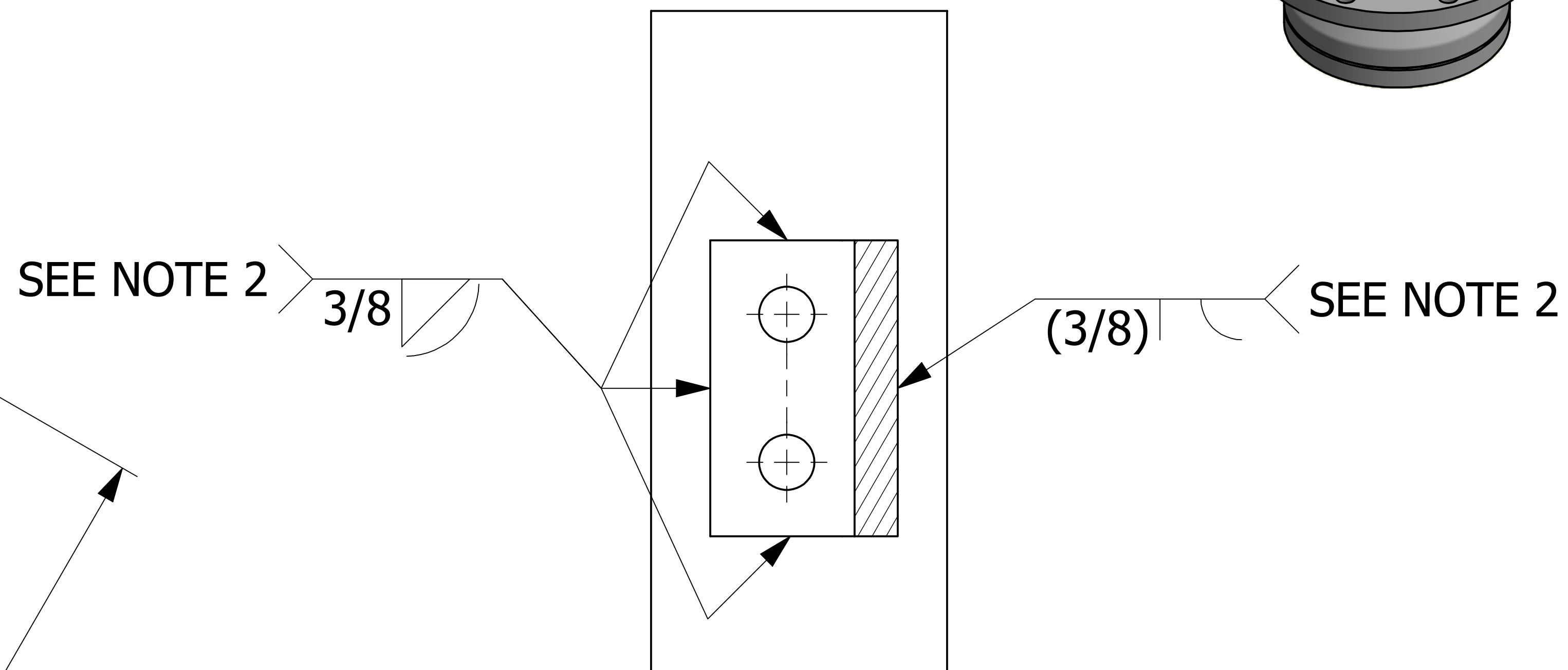
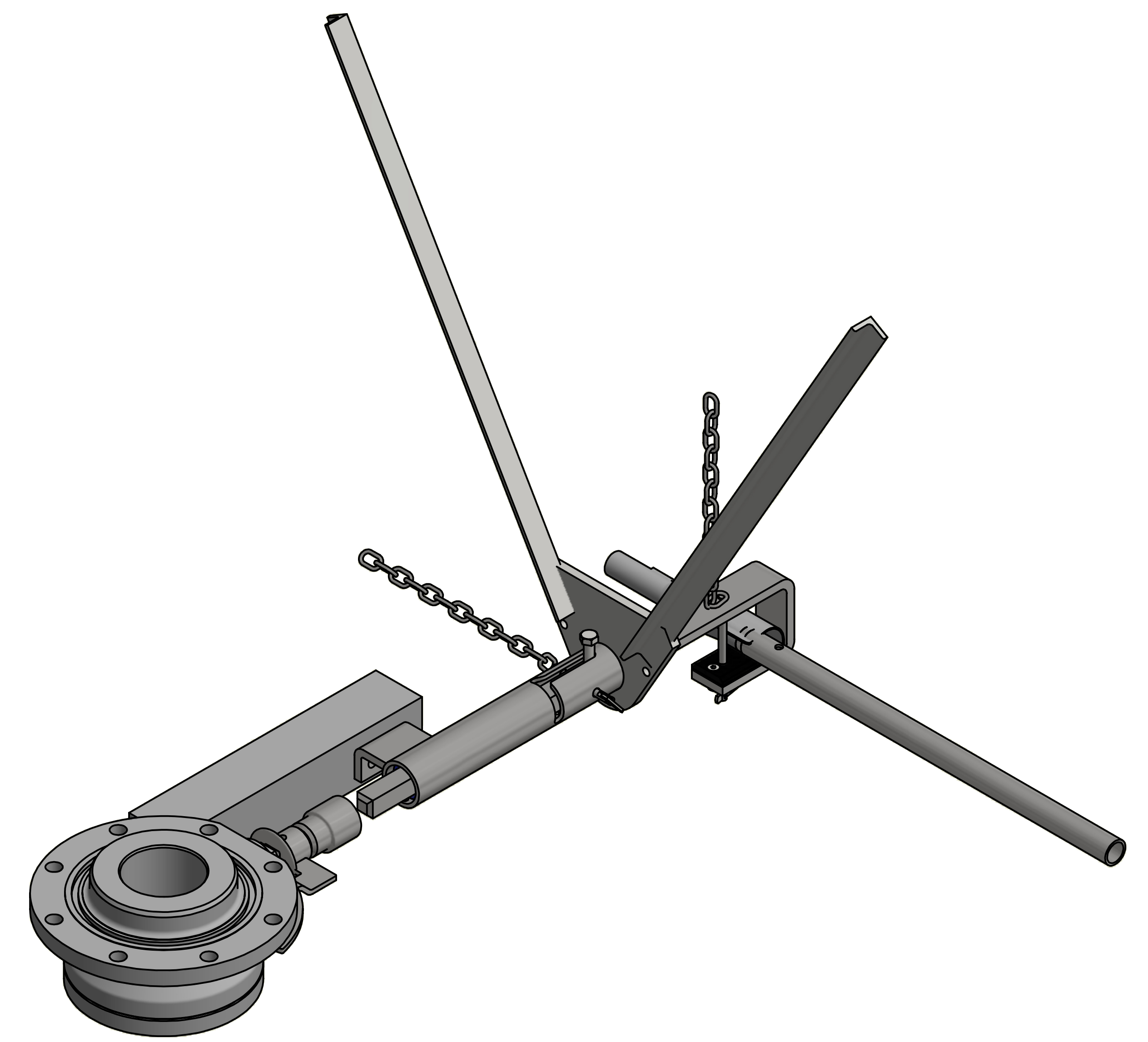
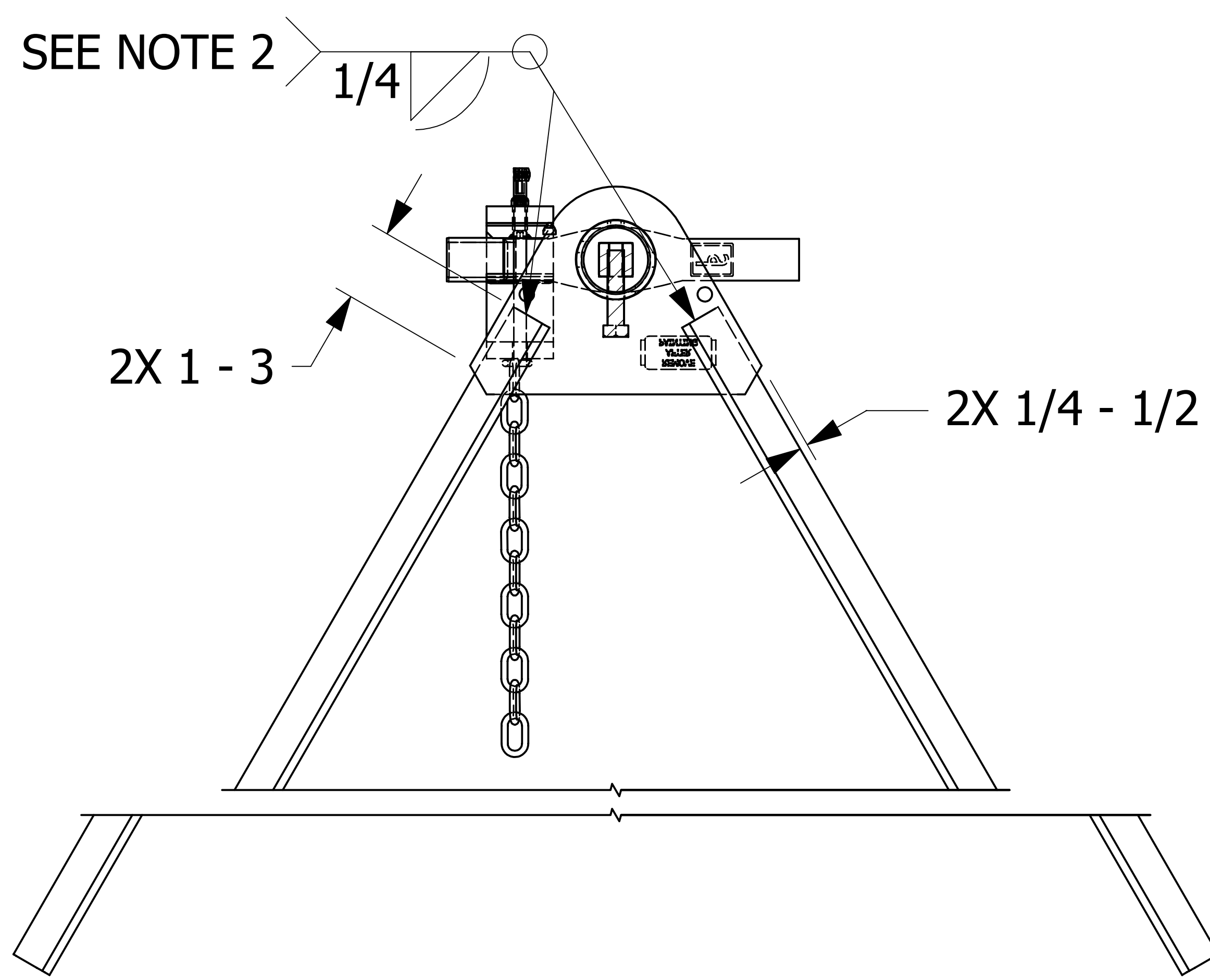
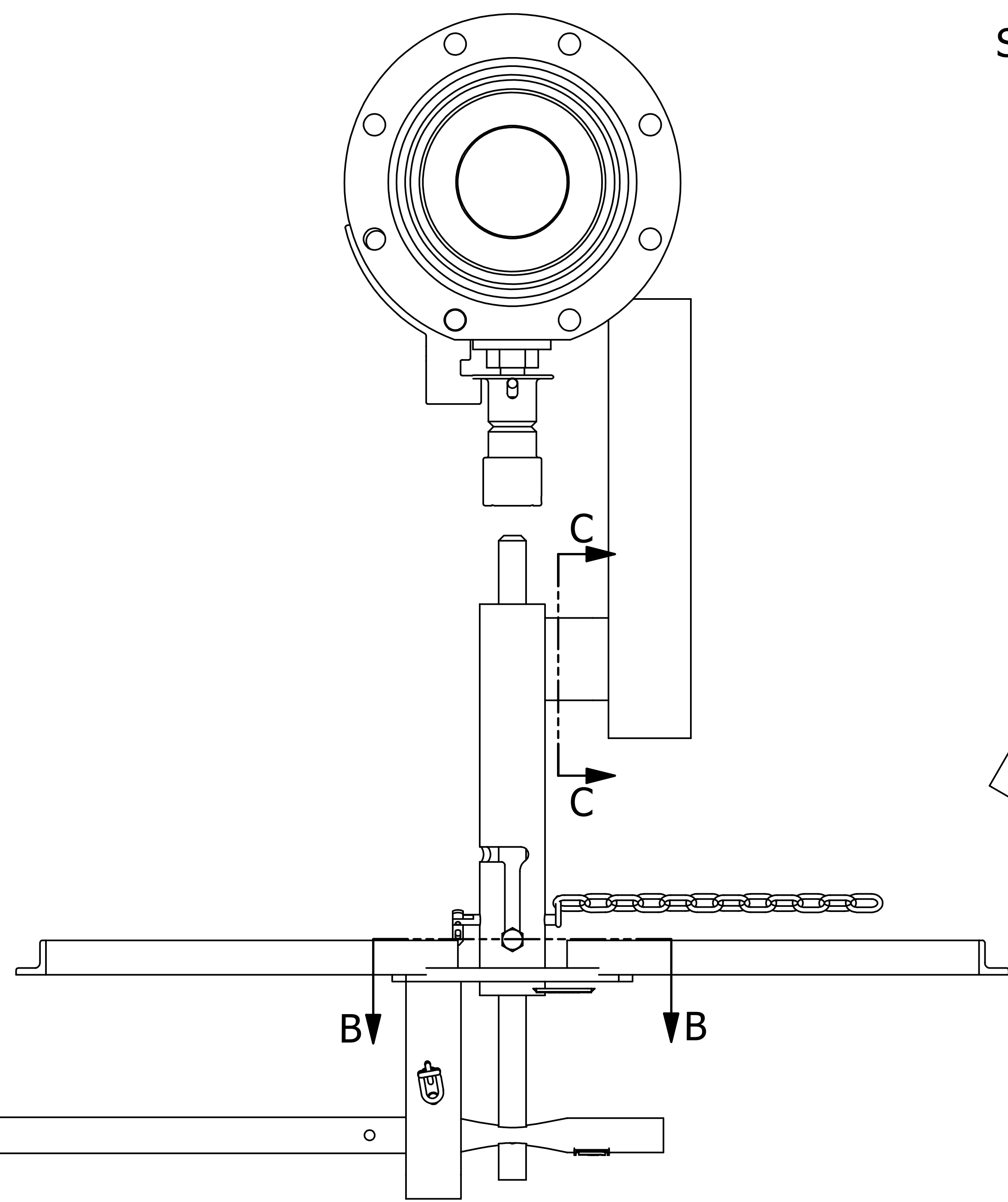

Ø7/16" HOLE FOR CHAIN LINK ATTACHMENT

REV	BY	DATE	DESCRIPTION
D	WEB	4-6-18	ADDED TAG PLACEMENT DIMENSIONS, ADDED 1/8 TO TAG WELD, SORTED BOM, UPDATED WELD NOTES
C	WEB	5-23-17	ADDED NOTE TO DETAIL D, ADDED "SAFEGUARD™" TO NOTE 5, UPDATED PART NAME, ADDED DSS 12 NOTE
B	WEB	11-13-15	REPLACED DBOV2224V01 WITH DBOV2224V02
A	JG	8-31-15	RELEASED FOR PRODUCTION

UNLESS OTHERWISE SPECIFIED DIMENSIONAL TOLERANCES FRACTIONAL: ±1/16	DRAWN BY:	RJP
X.XX: ±.03	CHECKED BY:	EJF
X.XXX: ±.015	PROTOTYPE BY:	RJP
ANGULAR: ±1°	PROTOTYPE DATE:	8/26/2015
DEBURR ALL SHARP EDGES. ALL MACHINED SURFACES TO HAVE A 125 RMS FINISH UNLESS NOTED OTHERWISE.	APPROVED FOR PRODUCTION BY:	VD
THIRD ANGLE PROJECTION	PRODUCTION DATE:	8/31/2015

SALCO PRODUCTS, INC.

PART NAME: **SAFEGUARD™ BOV OPERATING SYSTEM**

MATERIAL: **SEE BOM**

PROJECT #:	140114T	SHEET #:	2 OF 2	SCALE:	1:3
DRAWING #:	E42194	PART #:	BOVHKITCSMCK03		