

NO.	PART NAME	PART#	REQ'D	MATERIAL
1	SPRING 21/32"X2"	A38818	1	18-8 SS
2	PIN 11/32" X 2"	A39986	1	304/316 SS
3	STICKER	A41924	1	VINYL
4	ANGLE IRON 1 1/4" X 1 1/4" X 1/4"	B31012	2	CS
5	ANGLE 3" X 3" X 3/8"	B39133	1	CS
6	BOV ADAPTER MCKENZIE	B39437	1	CS
7	LOCKING BRACKET	B39444	1	304 SS
8	HANDLE EXTENSION ASSEMBLY	BOVHECS03	1	CS/SS
9	SAFEGUARD™ BOV DECAL	DBOV2224V01	1	VINYL
10	TAG	TAGSS3	1	304 SS

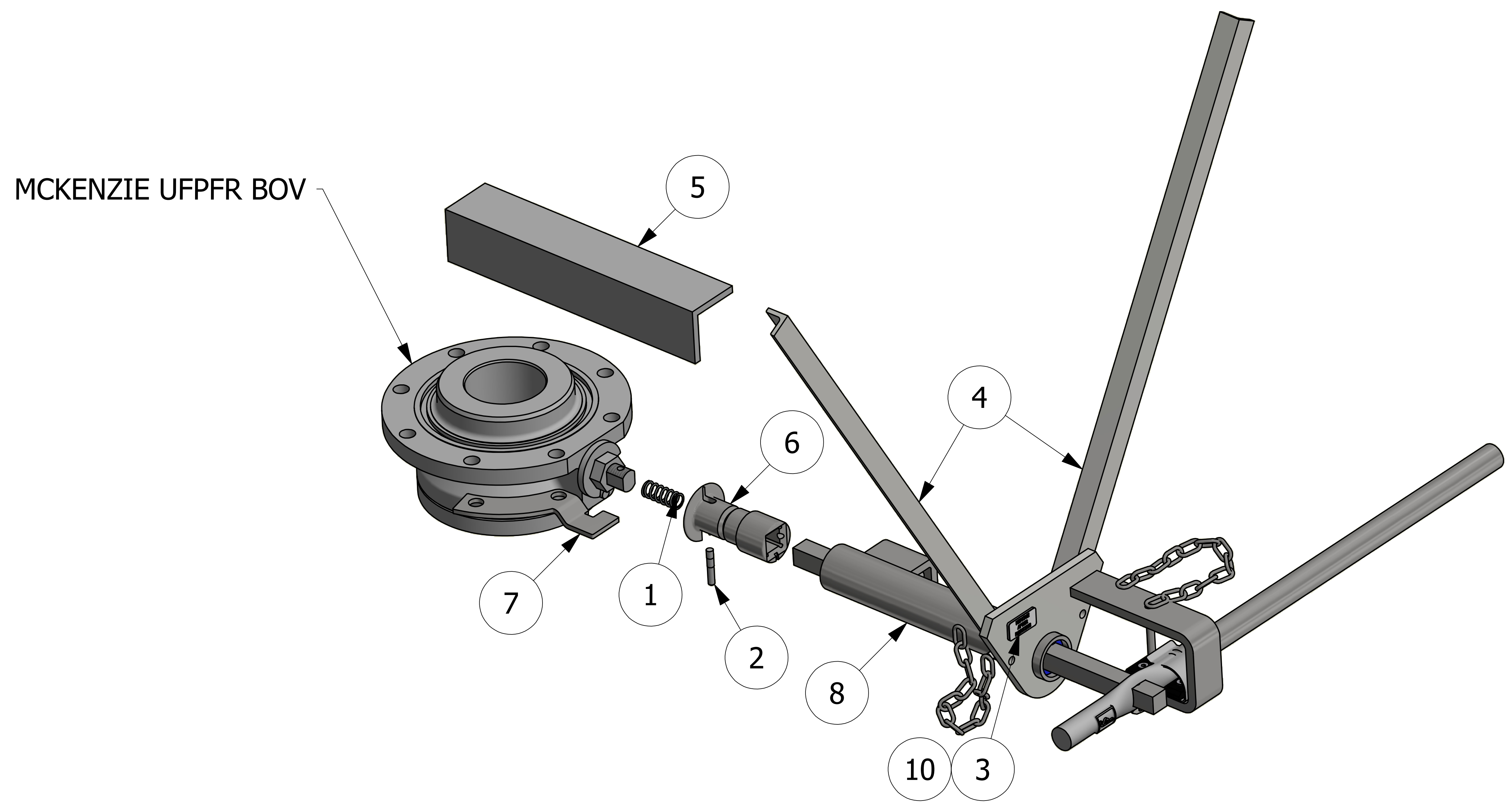
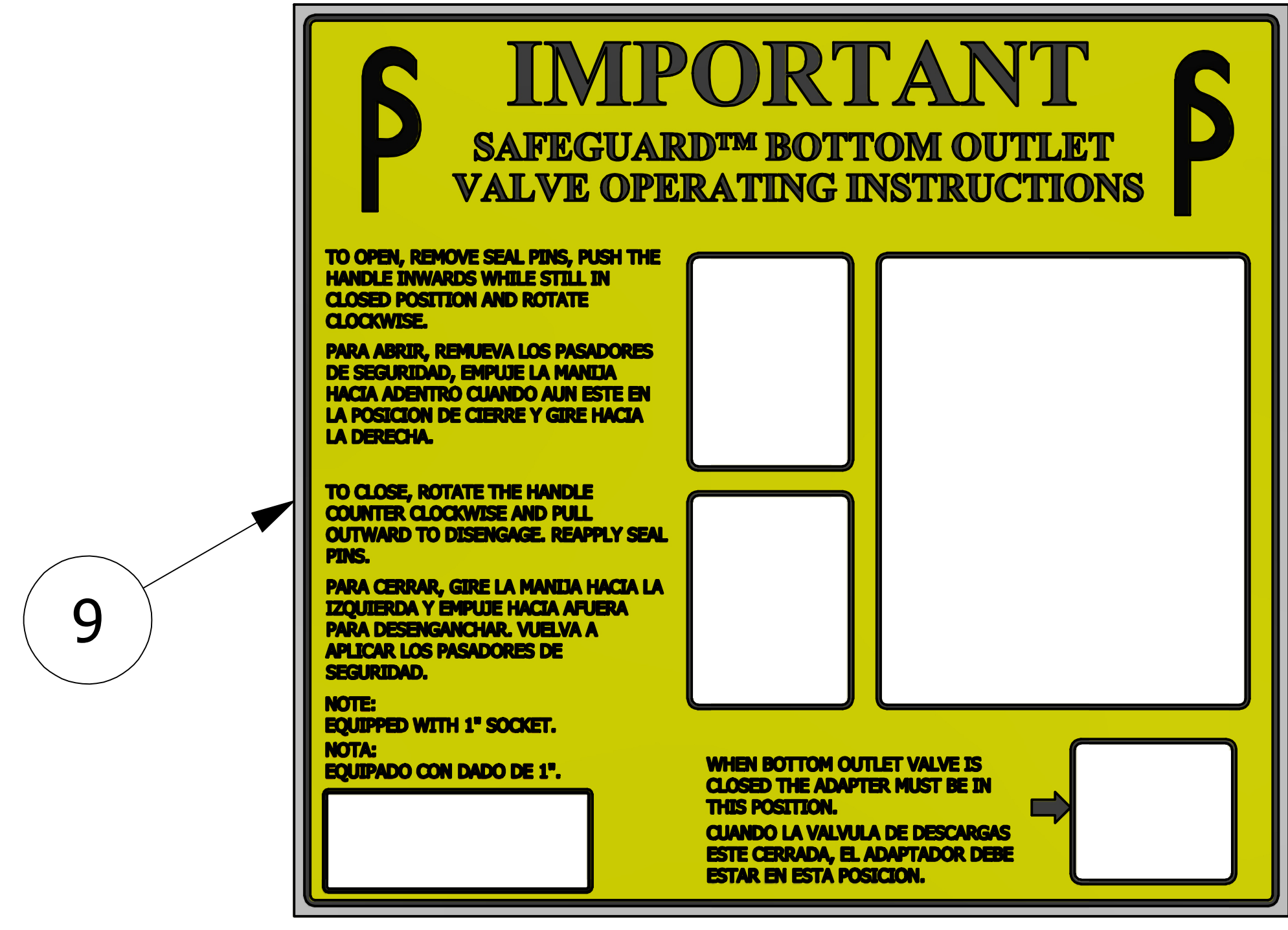

- NOTES:
1. VALVE SOLD SEPARATELY.
  2. WELDING OF BRACKETS WILL BE DONE UPON APPLICATION TO THE CAR IN ACCORDANCE WITH AWS D15.1.
  3. IF REQUIRED, CUSTOMER TO CUT MOUNTING BRACKETS TO LENGTH/ANGLE UPON APPLICATION TO THE CAR.
  4. ENGRAVE TAGSS3 WITH "SAFEGUARD™", "MCK04", AND DATE "\*\*\*/\*\*" (MONTH/YEAR). TEXT HEIGHT 1/4" MIN.
  5. WELD TAGSS3 PER DSS 12 WELDING SPECIFICATIONS.
  6. APPLY A41924 TO TAGSS3 AFTER IT HAS BEEN WELDED ON.
  7. PATENT PENDING.

REV	BY	DATE	DESCRIPTION
C	WEB	4-6-18	ADDED TAG PLACEMENT DIMENSIONS, ADDED 1/8 TO TAG WELD, SORTED BOM, UPDATED WELD NOTES
B	WEB	5-23-17	ADDED NOTE TO DETAIL D, ADDED "SAFEGUARD™" TO NOTE 5, UPDATED PART NAME, ADDED DSS 12 NOTE
A	JG	8-31-15	RELEASED FOR PRODUCTION

UNLESS OTHERWISE SPECIFIED DIMENSIONAL TOLERANCES FRACTIONAL: ±1/16	DRAWN BY:	RJP
X.XX: ±.03	CHECKED BY:	VD
X.XXX: ±.015	PROTOTYPE BY:	RJP
ANGULAR: ±1°	PROTOTYPE DATE:	8/26/2015
DEBURR ALL SHARP EDGES. ALL MACHINED SURFACES TO HAVE A 125 RMS FINISH UNLESS NOTED OTHERWISE.	APPROVED FOR PRODUCTION BY:	VD
THIRD ANGLE PROJECTION	PRODUCTION DATE:	8/31/2015

**SALCO PRODUCTS, INC.**

PART NAME: **SAFEGUARD™ BOV OPERATING SYSTEM**

MATERIAL: **SEE BOM**

PROJECT #: **140114T** SHEET #: **1 OF 2** SCALE: **1:3**

DRAWING #: **E42189** PART #: **BOVHKITCSMCK04**



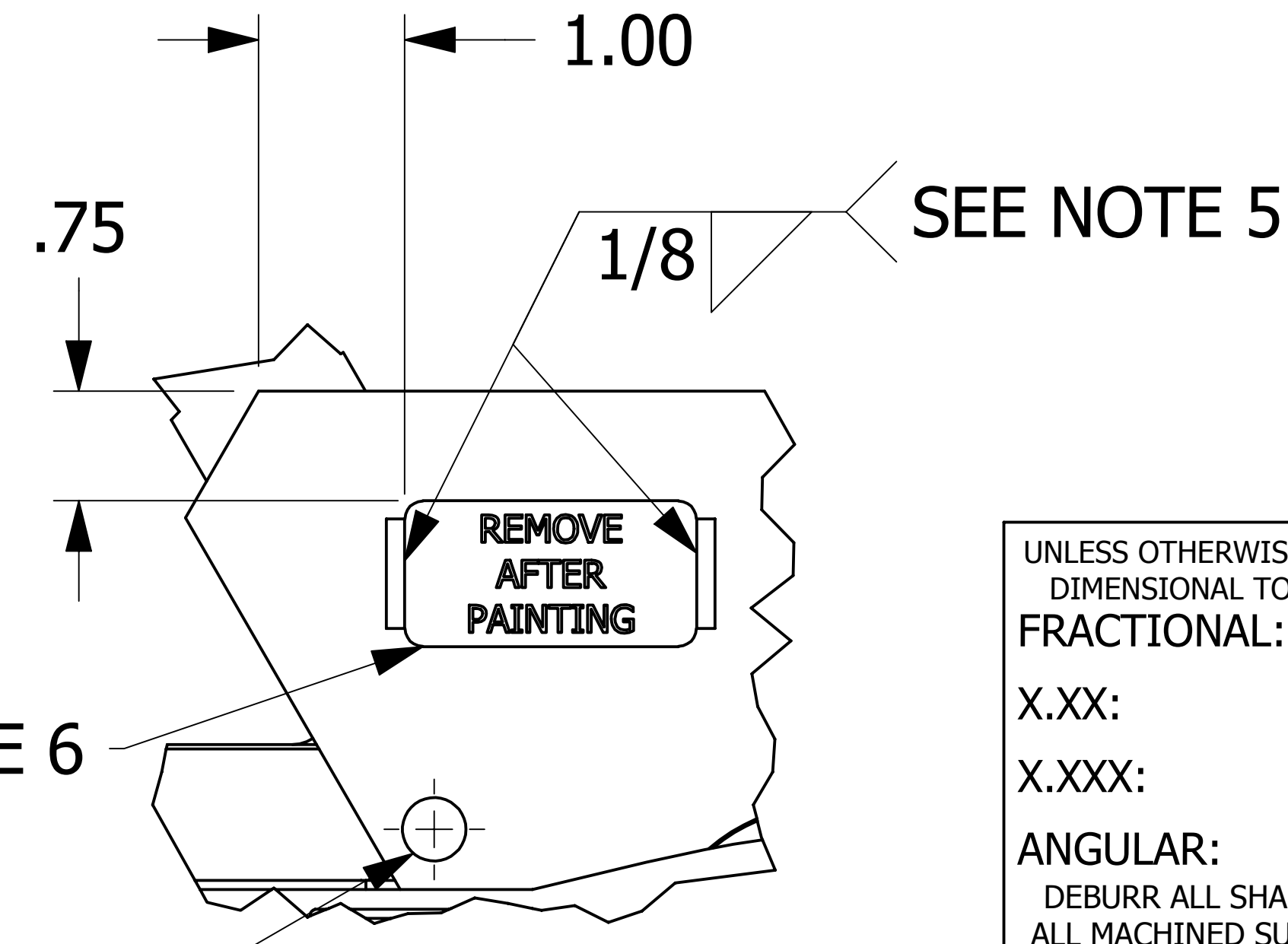
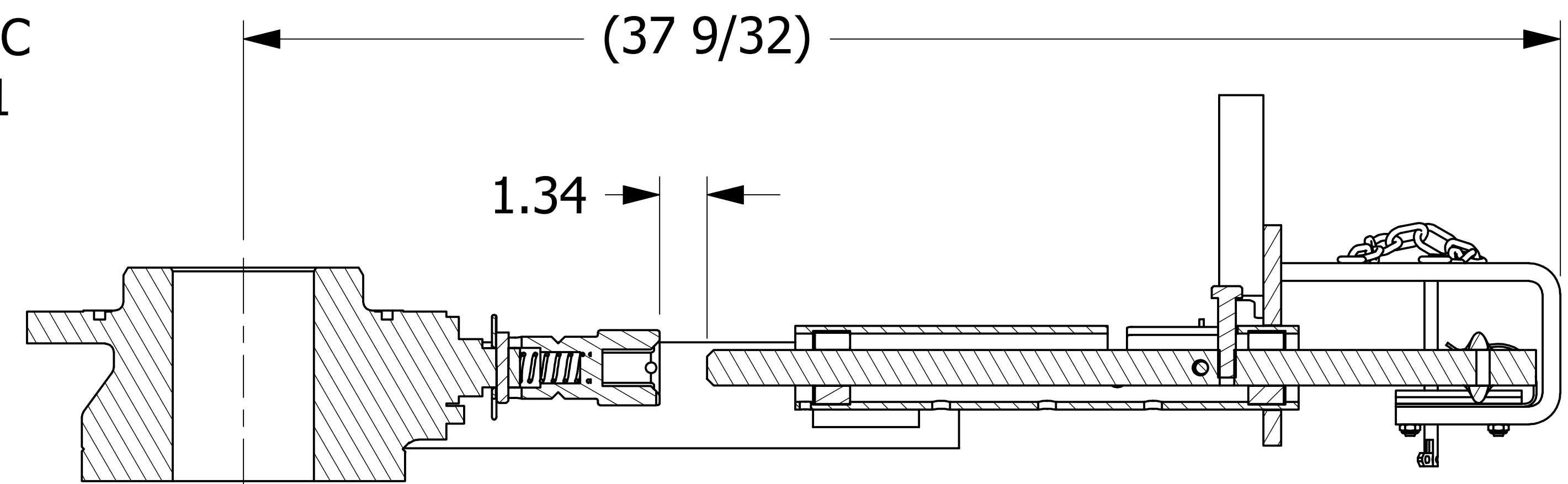
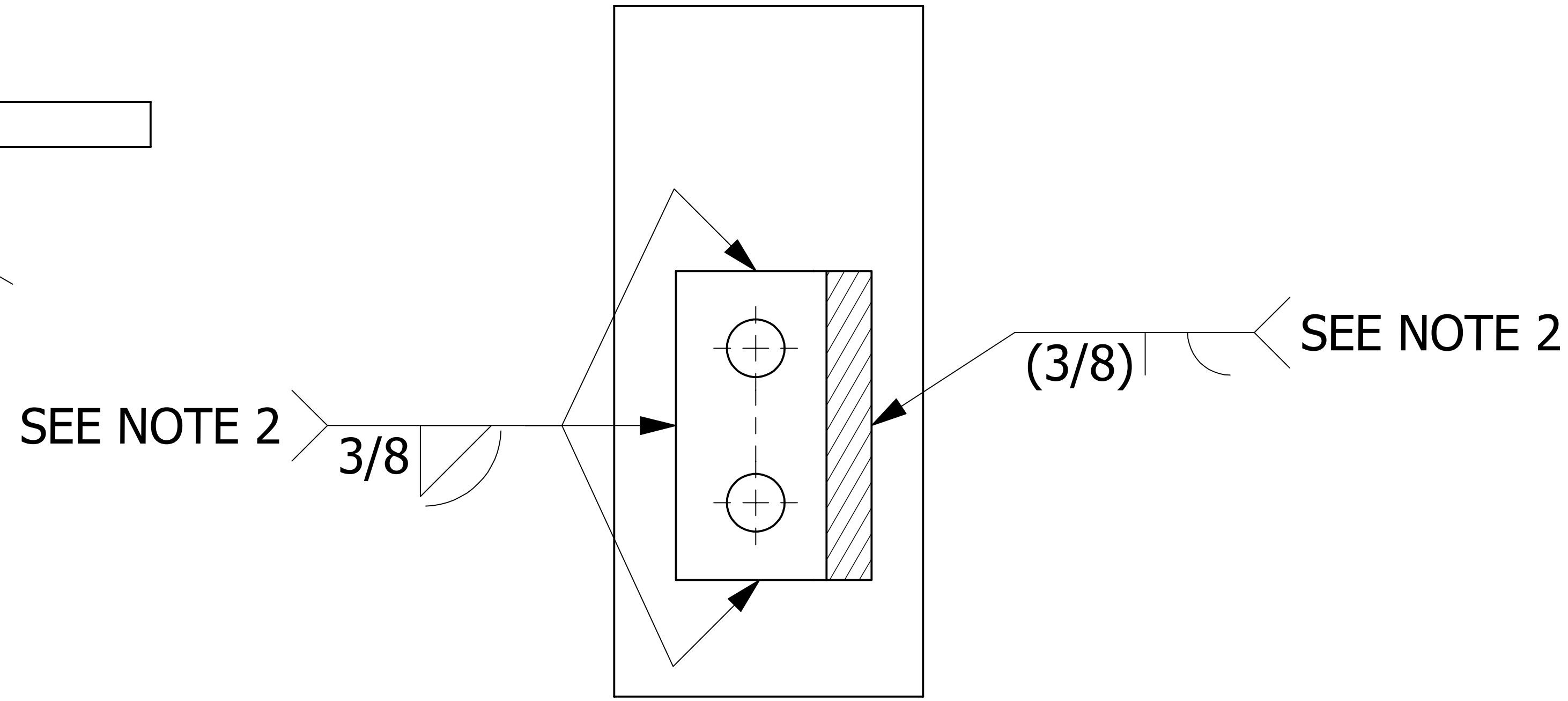
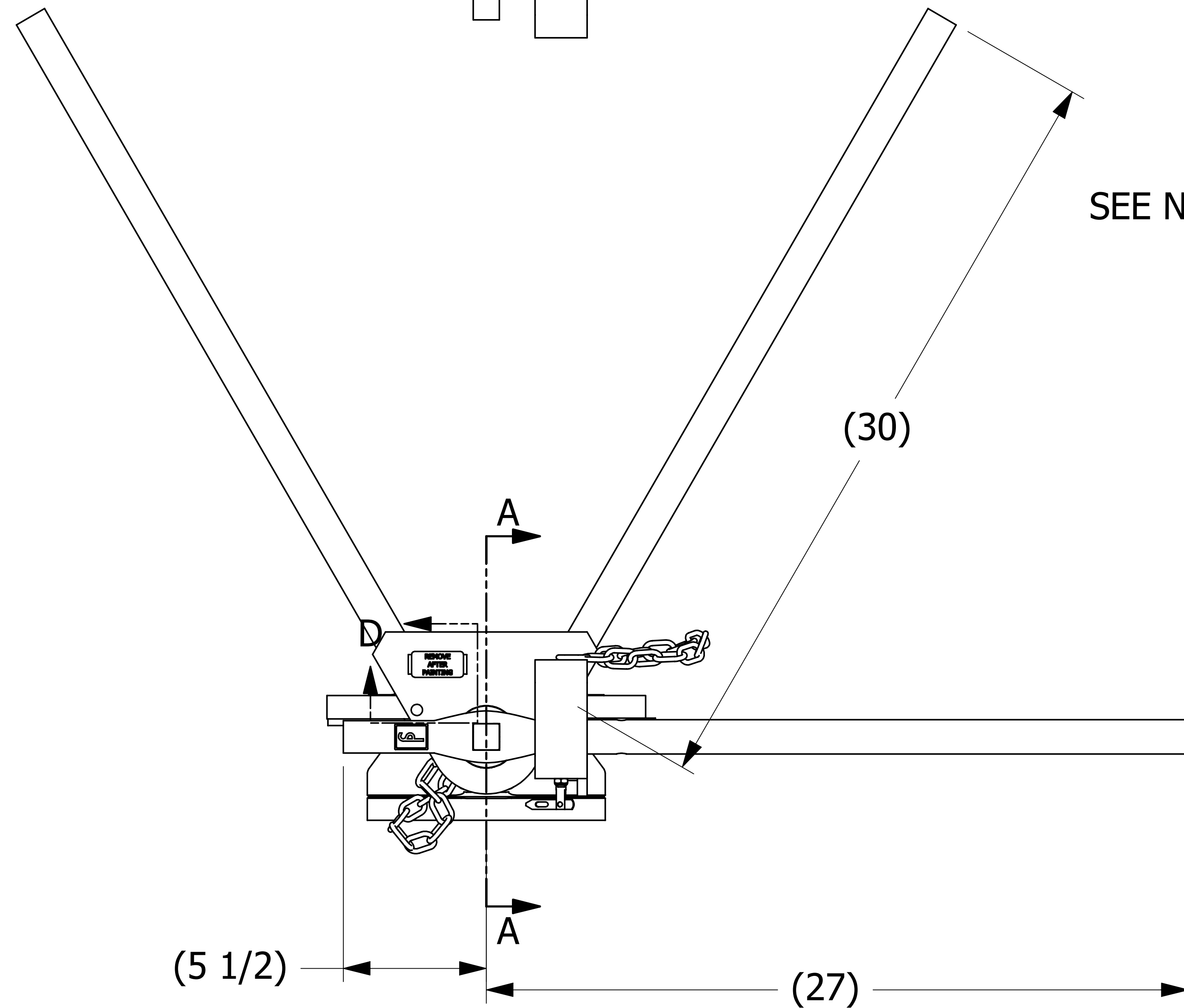
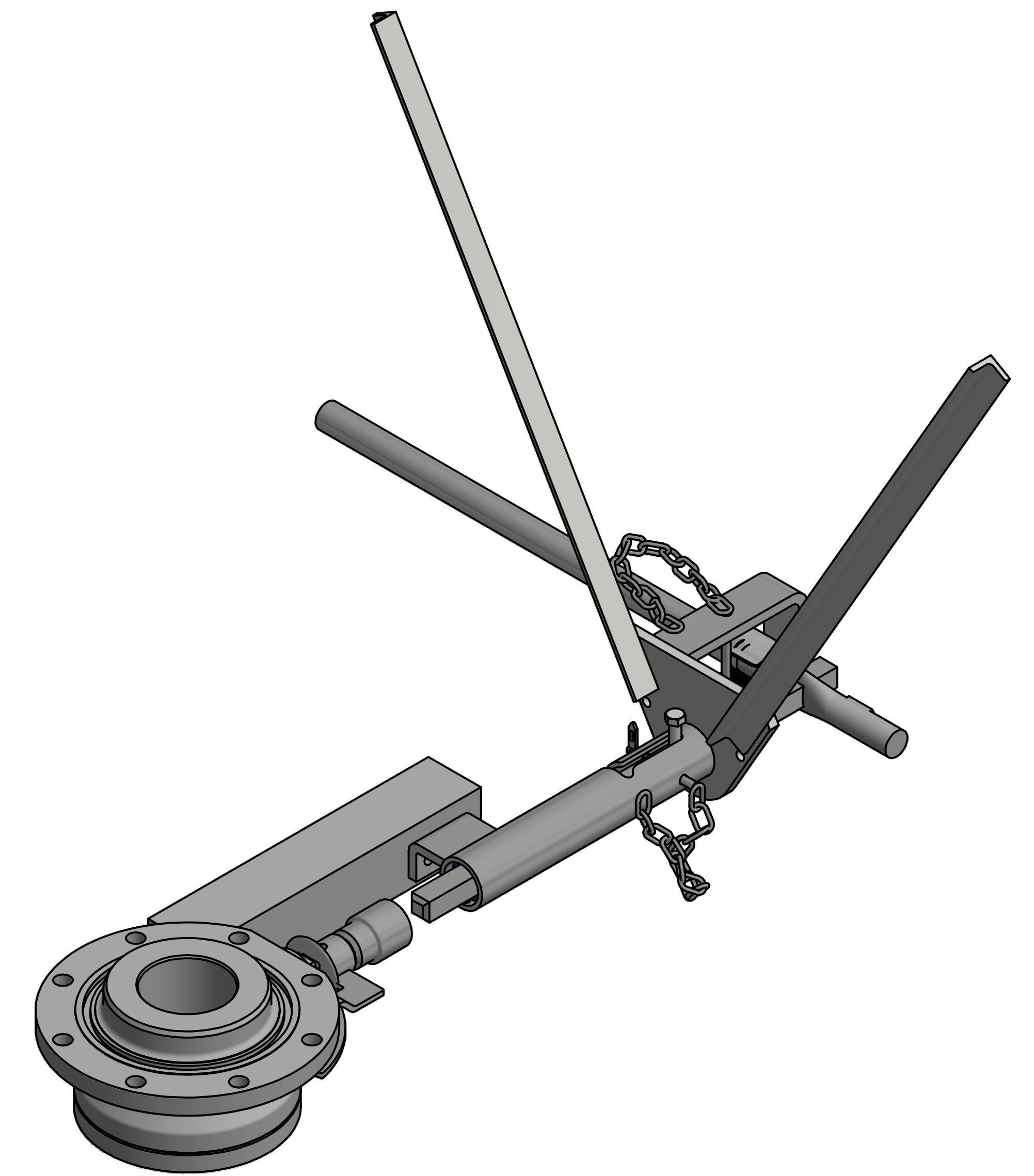
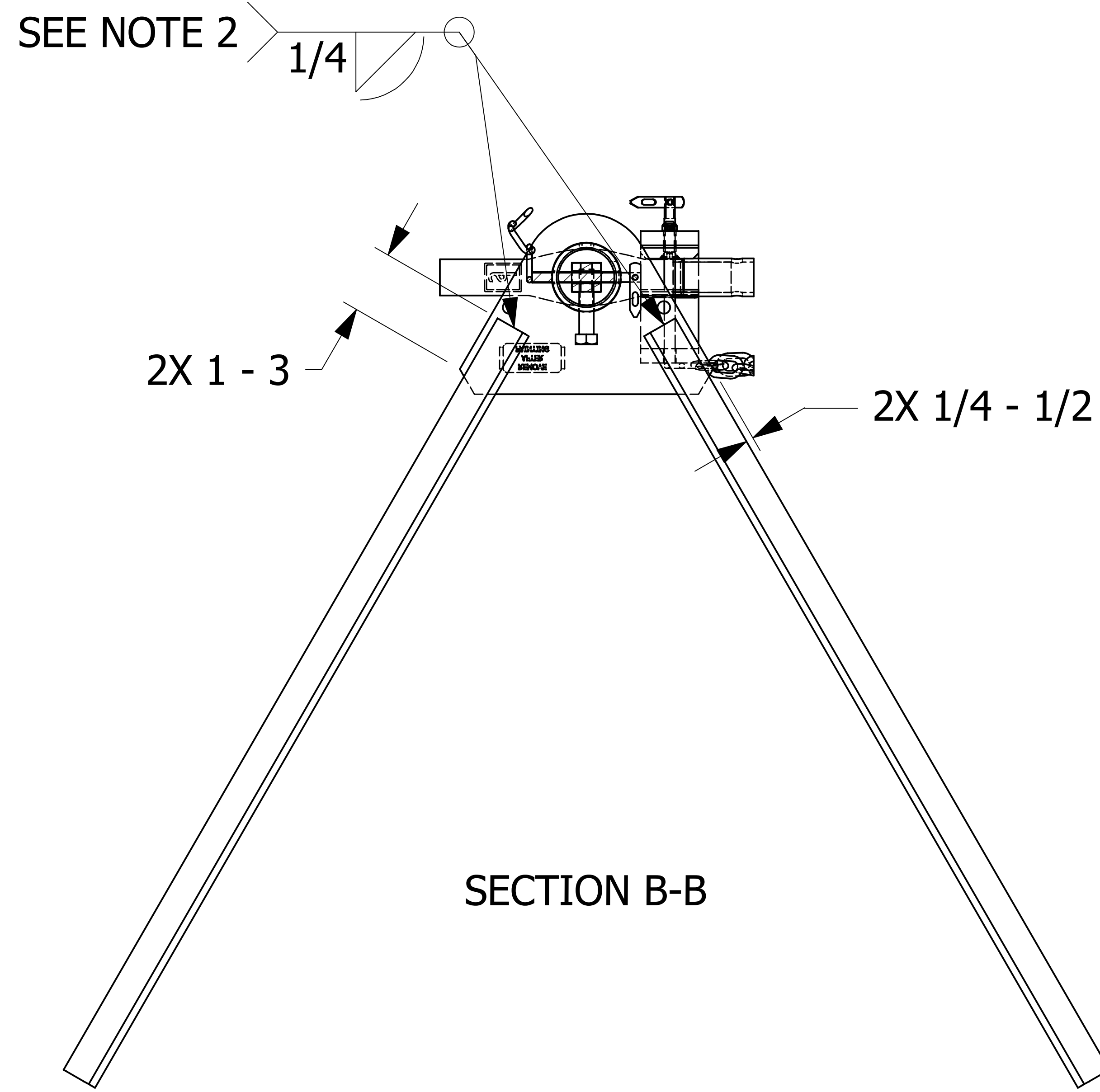
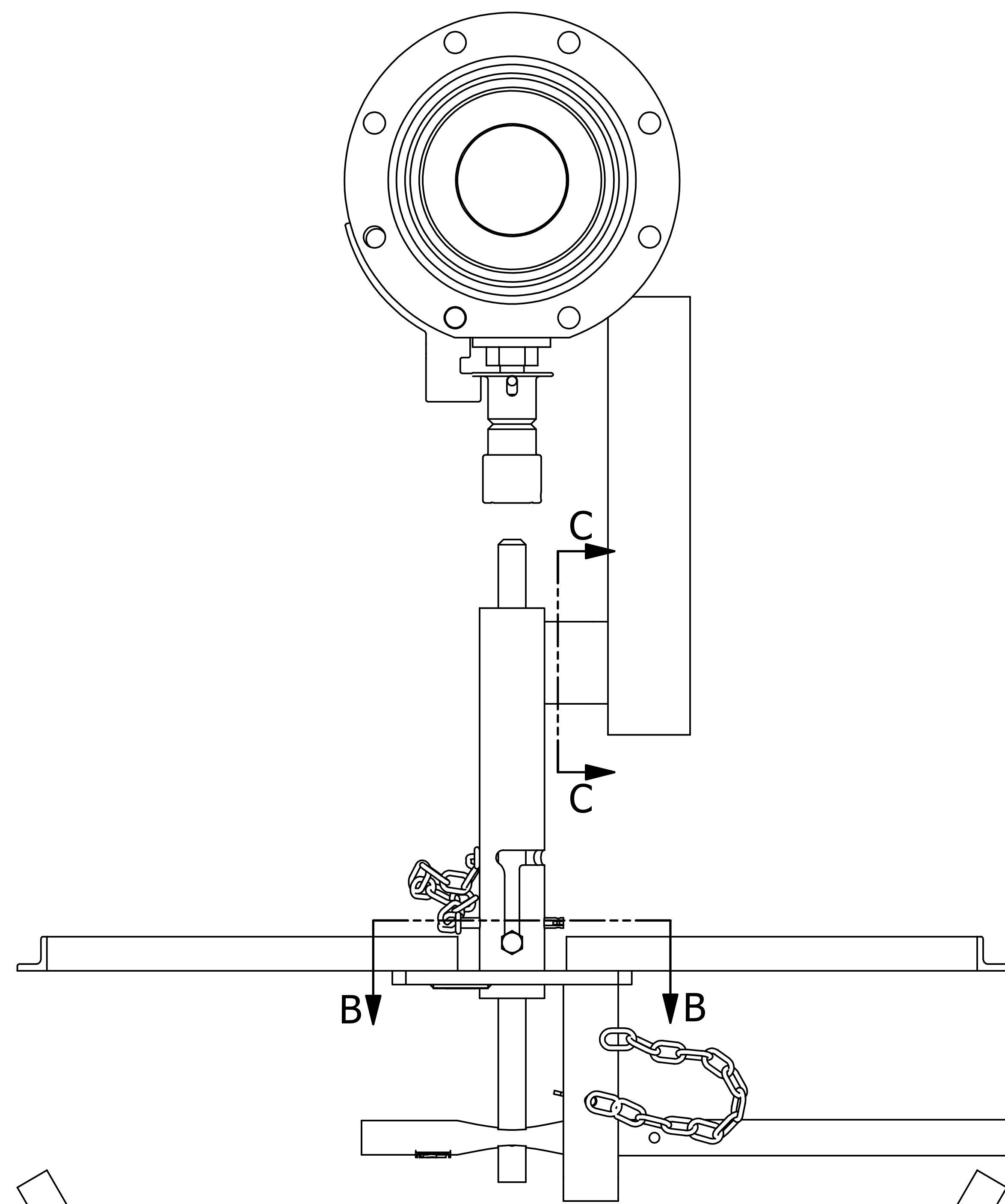

Ø7/16" HOLE FOR CHAIN LINK ATTACHMENT

SECTION A-A  
SCALE 1:2

REV	BY	DATE	DESCRIPTION
C	WEB	4-6-18	ADDED TAG PLACEMENT DIMENSIONS, ADDED 1/8 TO TAG WELD, SORTED BOM, UPDATED WELD NOTES
B	WEB	5-23-17	ADDED NOTE TO DETAIL D, ADDED "SAFEGUARD™" TO NOTE 5, UPDATED PART NAME, ADDED DSS 12 NOTE
A	JG	8-31-15	RELEASED FOR PRODUCTION

UNLESS OTHERWISE SPECIFIED DIMENSIONAL TOLERANCES FRACTIONAL: ±1/16 X.XX: ±.03 X.XXX: ±.015 ANGULAR: ±1° DEBURR ALL SHARP EDGES. ALL MACHINED SURFACES TO HAVE A 125 RMS FINISH UNLESS NOTED OTHERWISE. THIRD ANGLE PROJECTION	DRAWN BY: RJP
	CHECKED BY: VD
	PROTOTYPE BY: RJP
	PROTOTYPE DATE: 8/26/2015
	APPROVED FOR PRODUCTION BY: VD
	PRODUCTION DATE: 8/31/2015

**SALCO PRODUCTS, INC.**

PART NAME: **SAFEGUARD™ BOV OPERATING SYSTEM**

MATERIAL: **SEE BOM**

PROJECT #: **140114T** SHEET #: **2 OF 2** SCALE: **1:3**

DRAWING #: **E42189** PART #: **BOVHKITCSMCK04**