

(Ø7 1/2)  
TYP.

8X (Ø3/4)  
TYP.

(20 31/32)

(40 9/32)

(5 3/8)

SHEAR GROOVE

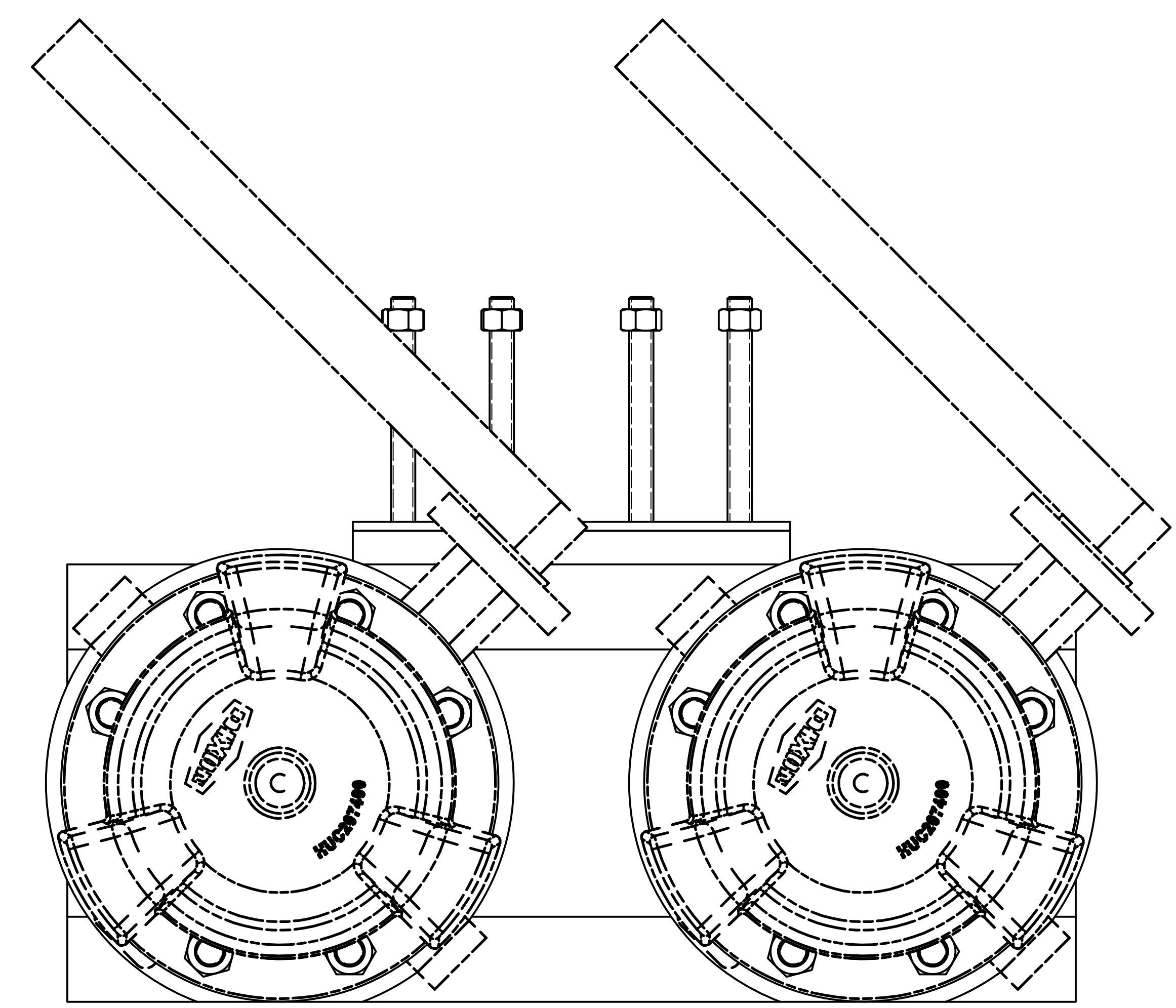

- NOTES:**
1. USE FASTORQ AG OR EQUIVALENT ANTI-GALL/ANTI-SEIZE LUBRICANT ON ALL STAINLESS STEEL FASTENERS.
  2. BUTTERFLY VALVES SOLD SEPARATELY.
  3. APPROXIMATE WEIGHT IS 100 LBS.

UNLESS OTHERWISE SPECIFIED  
DIMENSIONAL TOLERANCES  
FRACTIONAL: ±1/16  
X.XX: ±.03  
X.XXX: ±.015  
ANGULAR: ±1°  
DEBURR ALL SHARP EDGES.  
ALL MACHINED SURFACES TO  
HAVE A 125 RMS FINISH UNLESS  
NOTED OTHERWISE.

DRAWN BY: CHL  
CHECKED BY: EJF  
PROTOTYPE BY: CHL  
PROTOTYPE DATE: 2/22/2018  
APPROVED FOR PRODUCTION BY: VD  
PRODUCTION DATE: 3/19/2018

REV	BY	DATE	DESCRIPTION
C	WEB	7-5-18	REPLACED 8X STUD128SS W/ 8X STUD127SS
B	CHL	5-31-18	REPLACED 16X HN58S6 & STUD588SS W/FHN77714 & STUD128SS
A	CHL	3-19-18	RELEASED FOR PRODUCTION

**SALCO PRODUCTS, INC.**

PART NAME: <b>PIPE ASSEMBLY 4"</b>			
MATERIAL: <b>SEE BOM</b>			
PROJECT #:	H180221	SHEET #:	1 OF 2
DRAWING #:	E46716	PART #:	HSTTU46716
SCALE:	1:2		



NO.	PART NAME	PART#	REQ'D	MATERIAL
1	FLANGE GASKET 4" 150 LB	FG2415006	5	BLACK VITON A
2	HEX NUT 1/2"-13	FHN77714	16	316 SS
3	HEX NUT 5/8"-11	HN58S6	32	316 SS
4	PIPE ELBOW 4"X90°	HS4X90PE18	1	SALCO PE
5	PIPE MANIFOLD 4"X4"	HSPM4X4X201	1	SALCO PE
6	PIPE CLAMP 4"	PC4905CE	1	CS/EPDM
7	STUD 1/2"-13 X 7"	STUD127SS	8	18-8 SS
8	STUD 5/8"-11X7 1/2" FULL THREAD	STUD58712SS	16	18-8 SS
9	SEGMENTED WASHER 7 1/2"	WS75S03	6	304 SS

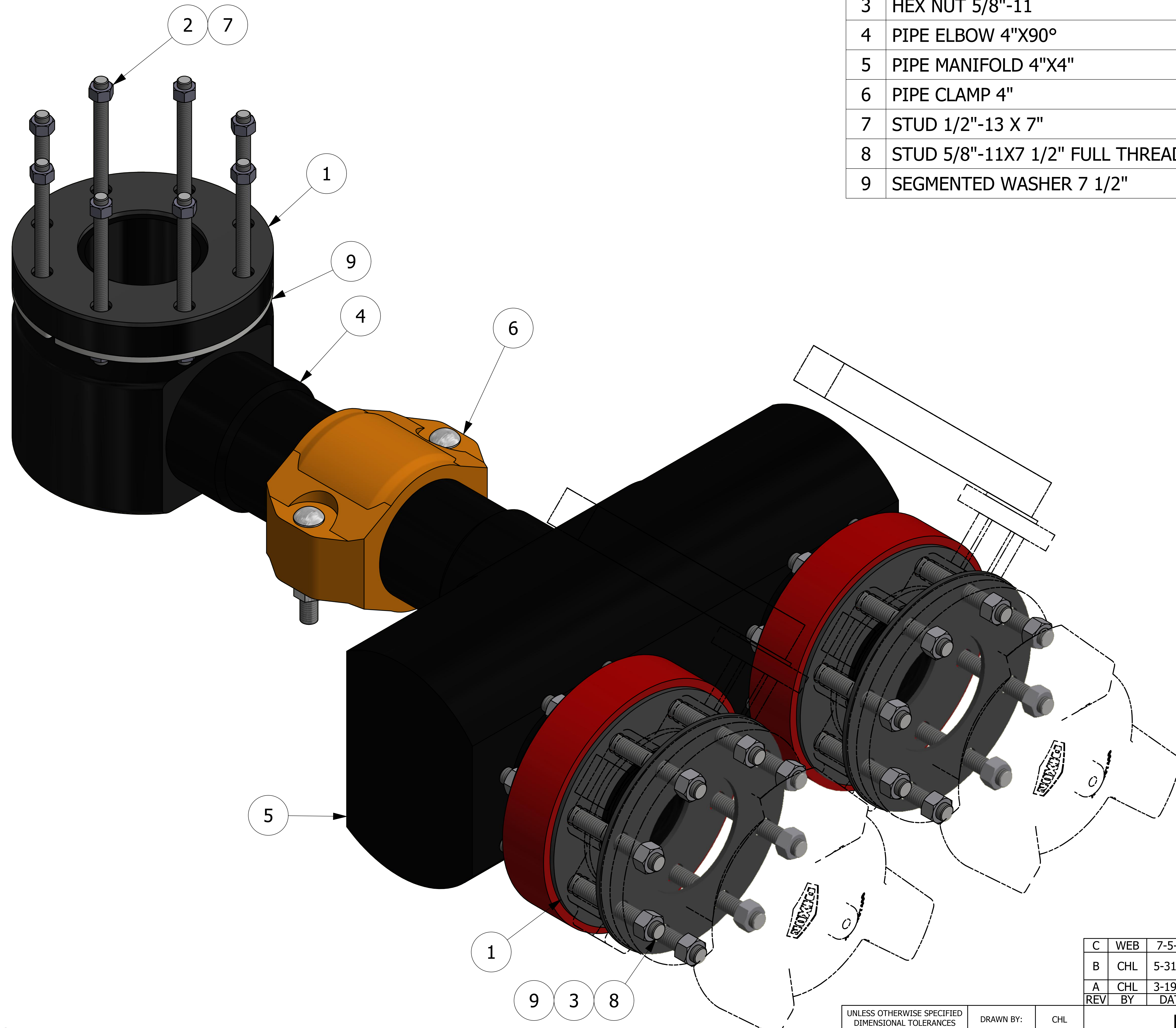

- NOTES:**
1. USE FASTORQ AG OR EQUIVALENT ANTI-GALL/ANTI-SEIZE LUBRICANT ON ALL STAINLESS STEEL FASTENERS.
  2. BUTTERFLY VALVES SOLD SEPARATELY.
  3. APPROXIMATE WEIGHT IS 100 LBS.

VIEW A-A  
SCALE 3:4

REV	BY	DATE	DESCRIPTION
C	WEB	7-5-18	REPLACED 8X STUD128SS W/ 8X STUD127SS
B	CHL	5-31-18	REPLACED 16X HN58S6 & STUD588SS W/FHN77714 & STUD128SS
A	CHL	3-19-18	RELEASED FOR PRODUCTION

UNLESS OTHERWISE SPECIFIED DIMENSIONAL TOLERANCES FRACTIONAL: ±1/16 X.XX: ±.03 X.XXX: ±.015 ANGULAR: ±1° DEBURR ALL SHARP EDGES. ALL MACHINED SURFACES TO HAVE A 125 RMS FINISH UNLESS NOTED OTHERWISE.	DRAWN BY: CHL
	CHECKED BY: EJF
	PROTOTYPE BY: CHL
	PROTOTYPE DATE: 2/22/2018
	APPROVED FOR PRODUCTION BY: VD
THIRD ANGLE PROJECTION	PRODUCTION DATE: 3/19/2018

**SALCO PRODUCTS, INC.**

**PIPE ASSEMBLY 4"**

**SEE BOM**

PROJECT #: H180221 SHEET #: 2 OF 2 SCALE: 1:2

DRAWING #: **E46716** PART #: **HSTTU46716**